



United States  
Department of  
Agriculture

Forest Service

Technology &  
Development  
Program

2300 Recreation  
May 2006  
0623-2801-MTDC



In cooperation  
with

United States  
Department of  
Transportation

Federal Highway  
Administration



# Accessibility Guidebook for Outdoor Recreation and Trails



*Cover photo—A father and son enjoy a  
hike in the woods on an accessible trail.*



# Accessibility Guidebook for Outdoor Recreation and Trails



**Janet Zeller**  
*Accessibility Program Manager*

**Ruth Doyle**  
*Santa Fe National Forest Landscape Architect*

**Kathleen Snodgrass**  
*Project Leader*

**USDA Forest Service**  
**Technology and Development Program**  
**Missoula, MT**

**4E42A85—FHWA Accessible Facility and  
Program Guidebook**

**May 2006**

This document was produced in cooperation with the Recreational Trails Program of the Federal Highway Administration, U.S. Department of Transportation.

This document is disseminated under the sponsorship of the U.S. Department of Transportation in the interest of information exchange. The United States Government assumes no liability for its contents or use thereof.

The contents of this report reflect the views of the authors, who are responsible for the accuracy of the data presented herein. The contents do not necessarily reflect the official policy of the Department of Transportation.

This report does not constitute a standard, specification, or regulation. The United States Government does not endorse products or manufacturers. Trade or manufacturer's names appear herein only because they are considered essential to the object of this document.



The Forest Service, United States Department of Agriculture (USDA), has developed this information for the guidance of its employees, its contractors, and its cooperating Federal and State agencies, and is not responsible for the interpretation or use of this information by anyone except its own employees. The use of trade, firm, or corporation names in this document is for the information and convenience of the reader, and does not constitute an endorsement by the Department of any product or service to the exclusion of others that may be suitable.

The U.S. Department of Agriculture (USDA) prohibits discrimination in all its programs and activities on the basis of race, color, national origin, age, disability, and where applicable, sex, marital status, familial status, parental status, religion, sexual orientation, genetic information, political beliefs, reprisal, or because all or part of an individual's income is derived from any public assistance program. (Not all prohibited bases apply to all programs.) Persons with disabilities who require alternative means for communication of program information (Braille, large print, audiotape, etc.) should contact USDA's TARGET Center at (202) 720-2600 (voice and TDD). To file a complaint of discrimination, write to USDA, Director, Office of Civil Rights, 1400 Independence Avenue, S.W., Washington, D.C. 20250-9410, or call (800) 795-3272 (voice) or (202) 720-6382 (TDD). USDA is an equal opportunity provider and employer.

# Acknowledgments

It has taken the effort of lots of people to integrate the various aspects of accessibility guidelines and the outdoor environment into one easy-to-use document. The authors gratefully acknowledge the contributions of those who provided advice and photographs:

**Pete Antos-Ketcham**, Green Mountain Club of the Appalachian Trail Conservancy

**Peter Axelson**, Beneficial Designs, Inc.

**Rory Calboun**, Washington State Interagency Committee for Outdoor Recreation

**Brad Cownover** Bureau of Land Management

**Christopher Douwes**, Federal Highway Administration

**Jill Gravinck**, Northeast Passage, University of New Hampshire

**Peggy Greenwell**, United States Access Board

**Peter Jensen**, Peter S. Jensen and Associates, LLC

**Thomas Kokx**, Thomas Kokx Associates

**Teresa Martinez**, Appalachian Trail Conservancy, Southwest and Central Virginia

**Holli McClain**, Bureau of Land Management

**Morgan Sommerville**, Appalachian Trail Conservancy, North Carolina

and Forest Service employees:

**Jim Beard**, Coconino National Forest

**Larry Blocker**, Northern Region

**Cathy Briggs**, National Forests in Florida

**Nancy Brunswick**, Cibola National Forest

**Mary Chislock**, Sequoia National Forest

**David Dercks**, Eastern Region

**Marti Dodds**, Prescott National Forest

**Chuck Frayer**, Pacific Northwest Region

**Mary Gebbart**, White Mountain National Forest

**Bill Hamele**, Washington Office

**Chris Hartman**, Intermountain Region

**Steve Hennig**, Alaska Region

**Bill Hughes**, Southern Region

**Thomas Iraci**, Pacific Northwest Region

**Debby Kriegel**, Coronado National Forest

**Nora Laughlin**, Alaska Region

**Patti Longmuir**, PEL Consulting

**Jim B. Miller**, Washington Office

**Lis Novak**, Intermountain Region

**Kim Round**, San Juan National Forest

**Jane Ruchman**, Gallatin National Forest

**Tom Savage**, Gifford Pinchot National Forest

**Karen Schroyer**, Wasatch-Cache National Forest

**Jaime Schmidt**, Chugach National Forest

**James Schwartz**, Washington Office

**Nancy Snoberger**, National Forests of Texas

**Shanay A. Stowe**, Sequoia National Forest

**Jim Thompson**, Northern Region

**Brian Vachowski**, Missoula Technology and Development Center

**Ramiro Villalvazo**, Washington Office

**Thomas E. Wright**, George Washington and Jefferson National Forest, Dry River Ranger District

**Alan Yamada**, San Dimas Technology and Development Center

The authors are indebted to the MTDC publications and support staff who created an attractive and easy-to-read report from our raw material: **Ian Grob**, **Heather Hall**, **Damien Hoffman**, **Jim Kautz**, **Bert Lindler**, **Sara Lustgraaf**, **Heather Matusiak**, **Jerry Taylor Wolf** and **Mary Trankel**. The authors are particularly grateful for the illustrations produced by **Deb Mucci**.



# ontents

<b>Introduction</b>	<b>1</b>
<b>The Outdoors Are for Everyone—Fundamentals of Outdoor Recreation and Trails Accessibility</b>	<b>2</b>
Why Accessibility Is Important	2
What Terms Should Be Used?	3
The Law Requires Accessibility	4
Universal Design	5
Program Accessibility	6
Transition Plans	8
Accessibility Evaluation Surveys	9
<b>So Many Guidelines, So Little Time—Applying Accessibility Guidelines to Your Site</b>	<b>11</b>
The History of Accessibility Guidelines	11
Current Accessibility Guidelines	11
Accessibility Guidelines Under Development	12
Guidelines for the Outdoor Environment	12
What If the Guidelines Appear to Conflict With Each Other?	14
<b>All the Rest—Other Important Tools for Accessible Recreation</b>	<b>18</b>
Built Environment Image Guide	18
Recreation Opportunity Spectrum	18
Wilderness Access Decision Tool	19
Appalachian Trail Conservancy’s <i>Backcountry Sanitation Manual</i>	19
Accessibility Guidebook for Outfitters/Guides Operating on Public Lands	19
Accessibility Guidebook for Ski Areas Operating on Public Lands	20
Cooperative Publications	20
Standard Forest Service National Trail Specifications	20
<i>Trail Construction and Maintenance Notebook</i>	20
Sidewalks and Trails	21
Equestrian Design Guidelines for Trails, Trailheads, and Campgrounds	21
The <i>Facilities Toolbox</i>	21
Infra	21
Recreation & Heritage Resources Integrated Business Systems	22
Deferred Maintenance	22
Construction and Maintenance Practices	23
<b>Designing Access Into the Outdoor Environment</b>	<b>25</b>
Terminology	25
The Purpose of the FSORAG and FSTAG	26



<b>Applying the Forest Service Outdoor Recreation Accessibility Guidelines</b>	<b>27</b>
Using the Conditions for Departure in the FSORAG	27
Getting From Here to There—Outdoor Recreation Access Routes	31
Slopes and Resting Intervals for ORARs	32
Surfaces for ORARs	34
Clear Tread Width and Passing Spaces for ORARs	35
Tread Obstacles on ORARs	37
Protruding Objects and ORARs	37
Openings in ORAR Surfaces	37
Edge Protection for ORARs	38
Getting to the Water—Beach Access Routes	38
Slopes and Resting Intervals for Beach Access Routes	40
Maneuvering Space for Beach Access Routes	40
Surface and Clear Tread Width on Beach Access Routes	41
Passing Spaces on Beach Access Routes	41
Changes in Level on Beach Access Routes	41
Protruding Objects on Beach Access Routes	41
Openings in Beach Access Routes	41
Edge Protection for Beach Access Routes	41
Providing Creature Comforts and Conveniences—Constructed Features	42
Reach Ranges and Operability Requirements	43
Grab Bars	46
Constructed Features for Picnic Areas	46
Picnic Units	46
Picnic Tables	47
Cooking Surfaces, Grills, and Pedestal Grills	49
Constructed Features for Developed Campgrounds	50
Camping Units	50
Camp Living Areas	50
Campground Parking Spurs	50
Parking Spurs for Double Camp Units	53
Camp Unit Identification	53
Camp Unit Tent Pads and Tent Platforms	54
Fire Rings, Fireplaces, and Wood Stoves	55
Utilities	56
Water Hydrants	57
Utility Sinks	58
Other Constructed Features	59
Benches	59
Trash, Recycling, and Other Essential Containers	60
Viewing Areas at Overlooks	61
Telescopes and Periscopes	63



Storage Facilities for Assistive Devices _____	64
Pit Toilets in General Forest Areas _____	65
Warming Huts _____	69
Outdoor Rinsing Showers _____	69
Signs _____	71
<b>Applying the Forest Service Trails Accessibility Guidelines _____</b>	<b>73</b>
Is It a Trail or an Outdoor Recreation Access Route? _____	73
Understanding Trail Terminology _____	74
Trail Construction Techniques _____	75
Using the Conditions for Departure in the FSTAG _____	76
Using the General Exceptions in the FSTAG _____	80
Documenting Decisions _____	82
<b>Technical Provisions—How To Make a Hiker/Pedestrian Trail Accessible _____</b>	<b>83</b>
Grade and Cross Slope for Trails _____	83
Resting Intervals on Trails _____	84
Surfaces of Trails _____	85
Clear Tread Width of Trails _____	85
Passing Spaces on Trails _____	86
Tread Obstacles on Trails _____	86
Protruding Objects and Trails _____	87
Openings in Trail Surfaces _____	87
Edge Protection for Trails _____	88
Signs for Trails _____	89
<b>Constructed Features Associated With Trails _____</b>	<b>90</b>
<b>Overview of the FSTAG Implementation Process _____</b>	<b>91</b>
<b>Overview Chart of the FSTAG Implementation Process _____</b>	<b>97</b>
<b>Acronyms _____</b>	<b>104</b>
<b>Definitions _____</b>	<b>105</b>
<b>Resources _____</b>	<b>107</b>
Source Documents _____	107
Links _____	107
<b>Tips in This Guidebook _____</b>	<b>110</b>

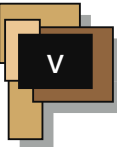

**T**his document is intended to help Forest Service personnel apply the Forest Service Outdoor Recreation Accessibility Guidelines and Forest Service Trail Accessibility Guidelines. These guidelines only apply within National Forest System boundaries. Both are based on the draft accessibility guidelines for outdoor developed areas created by the Architectural and Transportation Barriers Compliance Board (Access Board).

When the Access Board finalizes its accessibility guidelines for outdoor developed areas, the Forest Service will revise the Forest Service Outdoor Recreation Accessibility Guidelines and the Forest Service Trail Accessibility Guidelines to incorporate the Access Board's standards, where those provisions are a higher standard, as supplemented by the Forest Service. The supplementation will ensure the agency's application of equivalent or higher guidelines and universal design, as well as consistent use of agency terminology and processes.

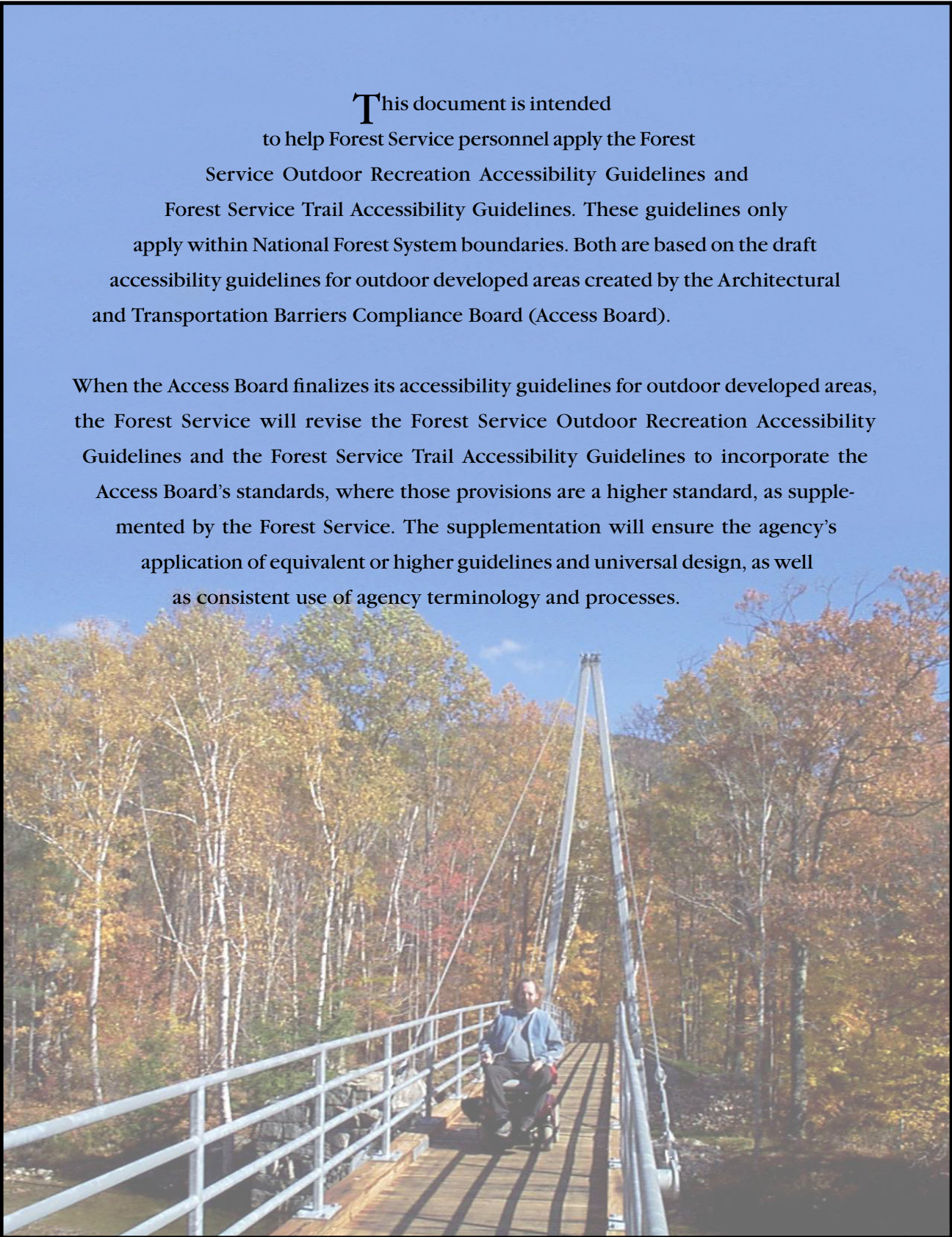





# Introduction

Lots of directives, letters, and books on accessibility have been written. A new batch appears every time guidelines or policies change.

This guidebook is intended to help designers and recreation professionals apply the Forest Service Outdoor Recreation Accessibility Guidelines (FSORAG) and Forest Service Trail Accessibility Guidelines (FSTAG). These guidelines only apply on National Forest System lands. While they are official policy only for the U.S. Department of Agriculture (USDA) Forest Service, they contain useful concepts to help other agencies and organizations develop accessible outdoor recreation and accessible trails.

Once managers and designers understand what is needed, accessibility becomes integrated into the thinking, planning, designing, construction, and maintenance of every project, rather than being an afterthought. That's the way we need to do business, and that's why this guidebook was written.

Coordination among Forest Service employees and with volunteer partners will be essential to successfully imple-

menting the FSORAG and FSTAG. The Forest Service is committed to helping ensure that the FSORAG and FSTAG are implemented.

Both the FSORAG and the FSTAG are based on the draft accessibility guidelines for outdoor developed areas created by the Architectural and Transportation Barriers Compliance Board (Access Board). The Forest Service and other Federal agencies will work with the Access Board as it develops final accessibility guidelines for outdoor developed areas. When the Access Board finalizes its accessibility guidelines for outdoor developed areas, the Forest Service will revise the Forest Service Outdoor Recreation Accessibility Guidelines and the Forest Service Trail Accessibility Guidelines to incorporate the Access Board's standards, where those provisions are a higher standard, as supplemented by the Forest Service. The supplementation will ensure the agency's application of equivalent or higher guidelines and universal design, as well as consistent use of agency terminology and processes. Once the guidelines are final, any changes that are needed will be made to this guidebook and it will be reissued.

# The Outdoors Are for Everyone—Fundamentals of Outdoor Recreation and Trails Accessibility

It's all about people having the opportunity to enjoy the outdoors. Public lands offer a wide range of recreation settings and opportunities from highly developed campgrounds to untouched wilderness areas.

when the decision is made to construct or alter a building, trail, or other facility, we must ask, "Will a person with a disability have an equal opportunity to use this facility?" The key is to ask this question before the facility has been designed and built. Then we can provide facilities for use by all people, including people with disabilities.

## Why Accessibility Is Important

The Forest Service is committed to integrating accessibility into the complete range of recreation opportunities while protecting natural resources and settings so that all people, including people who have disabilities, have the opportunity to enjoy the great outdoors. This commitment is established in Forest Service policy. Visitors have the right to choose both the type of recreation they want to pursue and the setting in which to pursue it. Of course, recreationists must always check to make sure that what they want to do is allowed.

How many people benefit from accessible facilities? At the time of the 2000 census, 54 million people, or one in every five people in the United States, had a disability that significantly limited one or more major life activities such as walking, seeing, hearing, breathing, thinking, and so forth. Of that number, 4 percent used wheelchairs and 7.4 percent used crutches, canes, walkers, or other assistive devices.

How does accessibility fit into this range of opportunities? We certainly don't want to pave the wilderness. However,

Additionally, the population of the United States is aging. By the year 2030, 110 million people will be older than 55. As people age, impairments are more likely to hinder activities. There's a lot of truth to the saying that if you live long enough, you are sure to join the ranks of people with disabilities.

## *Recreation Opportunities on National Forests and Grasslands*

- National forests and grasslands are in all but six of the United States and in Puerto Rico and the Virgin Islands.
  - 175 national forests and grasslands
  - 192 million acres (77.7 million hectares) to enjoy
- 406 congressionally designated wilderness areas
  - 35.2 million acres (14.2 million hectares) in which to experience solitude and a pristine environment
- 95 wild and scenic rivers
  - 4,418 miles (7,110 kilometers) of beautiful water to float or fish
- 133,000 miles (214,000 kilometers) of trails to hike
- 23,000 developed recreation areas
  - 4,300 campgrounds in which to pitch a tent or set up a trailer or recreational vehicle
- Thousands of miles (or kilometers) of scenic byways to drive
- 205 million visits each year

For more information on Forest Service recreation opportunities, visit <http://www.fs.fed.us/recreation/>.



If anyone in a group has a disability, accessibility is an issue for the whole group, as shown in figure 1. It influences where the group can go and what they can do. Ski areas learned many years ago that each skier who has a disability is usually accompanied by three or four additional skiers who don't have disabilities. They all want to buy lift tickets, rent gear, eat lunch, and ski together. Accessibility is good customer service and good for business.



Figure 1—Although the Blackberry Crossing Campground in the White Mountain National Forest is not highly developed, it's a great place for this group of friends to enjoy camping together.

Just as recreational preferences vary among the general population, people with disabilities enjoy different types of outdoor recreation. We must make sure that facilities allow all visitors, including people with disabilities, to choose their own recreational activities.

## What Terms Should Be Used?

Although people who have disabilities refer to themselves in many different ways, as an agency we must ensure that the terminology we use complies with legal direction and is considered acceptable by the majority of people. Numerous “buzz words” have been used to describe

people with disabilities over the years. The good news is that the terminology question was settled in the early 1990s. The 1990 Americans with Disabilities Act (ADA) uses the terms *persons with disabilities* and *accessible*. In 1992, when Section 504 of the Rehabilitation Act was renewed and amended, its terminology was corrected to include just the terms *accessible* and *persons with disabilities*. Also in 1992, Federal agencies were directed to correct terminology in their regulations, policies, and other documents to match the Rehabilitation Act and ADA terminology.

A disability is a medically definable condition that causes a limitation in one or more of a person's major life activities such as walking, seeing, hearing, speaking, breathing, thinking, and so forth. Person-first terminology is used because the person is more important than his or her disability. Examples of person-first terminology include:

- *A person who is blind—**not** a blind person*
- *A person who uses a wheelchair—**not** a wheelchair-bound person or a wheelchair person*

A handicap is a barrier or circumstance that makes progress or success difficult, such as a flight of stairs that may be impassable for a person using a wheelchair or a negative attitude toward a person who has a disability. The term *handicapped* has negative connotations. The word has been around for centuries, but wasn't used to refer to people with disabilities until the late 1800s. Many people believe that the term “handicapped” was first used in relation to persons with disabilities when Civil War veterans whose injuries prevented them from working were begging on the streets with “cap in hand.” Standard references do not support this story. But because the story has become legend and begging for a living is degrading, describing people with disabilities as *handicapped* is offensive to most people with disabilities. It may be useful to think of handicapped as the *H* word and eliminate it from your vocabulary, publications, and other materials.

### Disability Etiquette

- Use common sense and extend common courtesy to everyone.
- Don't patronize anyone; treat adults like adults.
- Be patient. Some people need more time to express themselves or move about.
- Relax and be yourself. It's okay to use common phrases such as "See you later" when talking with a person who is blind or has limited vision.
- Speak directly to the person and maintain eye contact, don't speak through a companion or interpreter.
- Use person-first language. Don't use words like handicapped, victim, or afflicted to describe a person who has a disability.
- Offer assistance to persons with disabilities and follow their specific directions.
- Do not pet, feed, or distract service animals without first asking permission—they are working animals, not pets.



Figure 2—Two friends enjoy an accessible trail that allows them to hike through the rain forest.

4

**Accessible facilities** comply with the accessibility guidelines and standards. A site, facility, or program is either accessible or it is not accessible. The only way to evaluate accessibility is to evaluate the facility's compliance with the guidelines in effect at the time it was designed, constructed, or altered. There are no shades of accessibility. For instance, a parking space either complies with the standards and is accessible, or it doesn't comply with the standards and is not accessible. The specific technical provisions of the standards for surfacing, slope, and the size of the parking space and walkway connection must be met, regardless of the conditions around the parking space. *Almost* doesn't count. For instance, figure 2 illustrates one type of trail that complies with accessibility guidelines.

Other terms concerning accessibility that are incorrect include *partially accessible*, *accessible with assistance*, *barrier free*, *ADA accessible*, and *handicapped accessible*. The first two terms are incorrect because a facility is either accessible or it is not accessible. If the facility is not accessible, the visitor or employee needs to know

which specific areas are not accessible. *Partially accessible* and *accessible with assistance* imply some accessibility problems, but don't provide enough information to be helpful. *Barrier free* isn't legally defined or commonly understood. *ADA accessible* confuses laws with accessibility standards. Although *handicapped accessible* is a common phrase, it includes the *H* word that many people with disabilities find offensive. *Handicapped accessible* also is a contradiction in terms because a handicap is a barrier and the term *accessible* means there aren't any barriers. The best terms are simply *accessible* and *not accessible*.

### The Law Requires Accessibility

The **Architectural Barriers Act** (ABA) (<http://www.access-board.gov/about/laws/ABA.htm>) became law in 1968. The act mandates that all facilities built, purchased, rented, altered, or leased by, for, or on behalf of a Federal agency must be accessible.

In 1973, the **Rehabilitation Act** became law. Section 504 (<http://www.access-board.gov/enforcement/Rehab-Act-text/title5.htm>) of the act applies to programs and activities that are conducted by Federal agencies and by entities that receive funding from, or operate under a permit from, Federal agencies. Section 504 requires that these programs and activities provide an equal opportunity for individuals with disabilities to participate in an integrated setting, as independently as possible. The only exception to the requirement is when the program would be fundamentally altered if changes were made solely for the purpose of accessibility. An example of a fundamental alteration to a program would be allowing use of a motor vehicle in an area not designated for motor-vehicle use.

The USDA implementation guideline for Section 504 is **7 CFR 15**, which was finalized in 1994. Part 15e ([http://www.access.gpo.gov/nara/cfr/waisidx\\_03/7cfr15e\\_03.html](http://www.access.gpo.gov/nara/cfr/waisidx_03/7cfr15e_03.html)) applies to programs conducted by the Forest Service. Subpart 15b ([http://www.access.gpo.gov/nara/cfr/waisidx\\_03/7cfr15b\\_03.html](http://www.access.gpo.gov/nara/cfr/waisidx_03/7cfr15b_03.html)) applies to programs operating with Federal agency funding, under special use permits, or under other agreements with the agency. If a building or structure must be entered for someone to participate in the activity at the site, the building must be accessible.

The **Americans with Disabilities Act (ADA)** (<http://www.access-board.gov/about/laws/ADA.htm>) became law in 1990. Except for Title V Section 507c, the ADA doesn't apply to Federal agencies' facilities and programs. They were already required to be accessible under the ABA and Section 504 of the Rehabilitation Act. The ADA applies to State and local government services and to public accommodations, such as motels and hotels, and organizations that are open to the public.

Title V Section 507c of the ADA applies to congressionally designated wilderness. It reaffirms the 1964 Wilderness Act and clarifies that agencies aren't required to change the character of wilderness areas to provide accessibility. Section 507c also defines a wheelchair and states that

wheelchairs meeting that definition can be used in congressionally designated wilderness.

## Universal Design

The best way to integrate accessibility is to use the principles of universal design. Universal design is simply designing programs and facilities to be usable by all people, to the greatest extent possible, without separate or segregated access for people with disabilities (figure 3). Using universal design principles is Forest Service policy, as stated in the Forest Service Manual, Section 2333.33 ([http://www.fs.fed.us/im/directives/fsm/2300/id\\_2330-2005-2.doc](http://www.fs.fed.us/im/directives/fsm/2300/id_2330-2005-2.doc)).



Figure 3—A group of friends enjoy a break during a stroll on a boardwalk through a wet area. The accessible trail makes it possible for the whole group to enjoy the same experience.

Since the early 1990s, the Forest Service has followed the universal design policy that all new and reconstructed facilities, programs, and associated elements are to be accessible to the greatest extent possible. This commitment often exceeds the minimum requirements of the



Federal accessibility guidelines. The result of universal design is independence, integration, and dignity for everyone.

More information on accessibility guidelines is provided in the next chapter.

## Program Accessibility

For the purposes of evaluating accessibility, a *program* is an activity in which people may participate. Basically, the program is the reason a person visits an area and may include opportunities such as:

- Camping in a campground
- Viewing the scenery at an overlook (figure 4)
- Swimming at a beach
- Enjoying solitude in the wilderness
- Gathering information at a visitor center
- Learning about an area on an interpretive trail

The 1994 USDA regulations—7 CFR 15e ([http://www.access.gpo.gov/nara/cfr/waisidx\\_03/7cfr15e\\_03.html](http://www.access.gpo.gov/nara/cfr/waisidx_03/7cfr15e_03.html)) and 15b ([http://www.access.gpo.gov/nara/cfr/waisidx\\_03/7cfr15b\\_03.html](http://www.access.gpo.gov/nara/cfr/waisidx_03/7cfr15b_03.html)) govern the USDA implementation of Section 504 of the Rehabilitation Act. They prescribe the requirements for ensuring access to programs.

If a program is provided inside a building or structure, everyone, including people with disabilities, must be able to enter the facility to participate in the program. Unfortunately, some older structures are not yet accessible, and a few cannot be made accessible because doing so would destroy their historic integrity. If a facility is not accessible, the program must be provided in another manner, called an alternative program. All alternative programs must allow everyone to participate together. Separate, segregated programs just for people with disabilities aren't permitted. For example, if an evening program at a campground previously has been held in an amphitheater that isn't accessible, the program must be moved to an accessible location until the amphitheater is accessible.

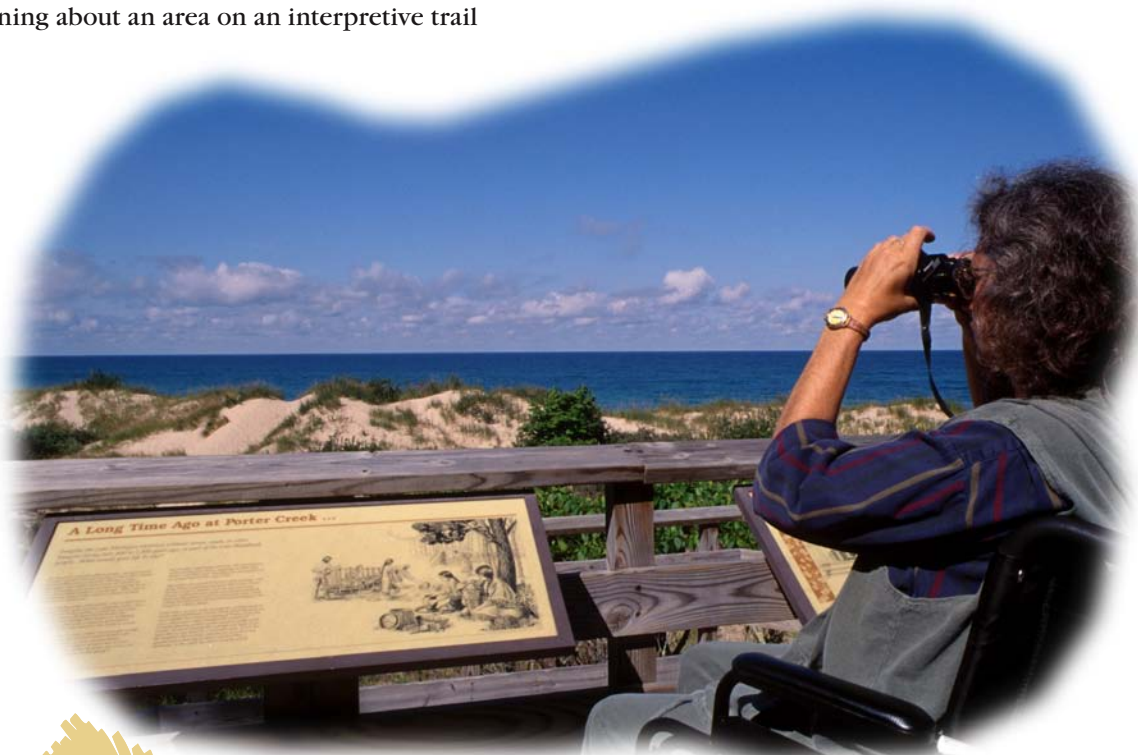

Figure 4—Interpretation is for everyone. Signs must be placed so that everyone can see and understand them.



Under Section 504 of the Rehabilitation Act and 7 CFR 15, access to programs that don't depend on constructed facilities also are required to provide "equal opportunity" to all. That means that a person with a disability cannot be denied the opportunity to participate in a program that is open to everyone. To participate, any person, with or without a disability, must meet the criteria for the program and abide by any restrictions, including those of the Forest Land Management Plan, for that program in that area. While people with and without disabilities are to have an equal opportunity to participate in programs and to strive to gain the same benefits offered by those programs, no guarantee of success is required.

The laws require equal opportunity; they don't require exceptional opportunity. For example, roads, trails, or other areas on national forests and grasslands that are not designated for motor-vehicle use under a forest travel management plan are closed to all motor vehicles, including those used by people with disabilities.

Access to programs must be viewed through the lens of the entire program, not through the eyes of an individual. Access to the program is to be provided so long as doing so doesn't "fundamentally alter" the program. That is, providing access doesn't change the primary functions of the program. Allowing motorized vehicles in a non-motorized area would be a fundamental alteration of the recreational program for that area.

People ask, "What about reasonable accommodation?" The laws are clear. Reasonable accommodation, which means doing whatever each individual needs to be able to fulfill the functions of a job, despite any disability, only applies in employment. It does not apply to recreation facilities and trails. The laws also are clear that when it comes to program access, the overall program is the focus. Criteria to participate in that program must be the same for all participants.

Questions often arise concerning the use of wheelchairs in areas that restrict or prohibit mechanical devices or

motorized use. As clarified in Title V Section 507, the *Federal Wilderness Areas* section of the Americans with Disabilities Act, the legal definition of a wheelchair is:

*A device designed solely for use by a mobility-impaired person for locomotion, that is suitable for use in an indoor pedestrian area.*

"Designed solely for use by a mobility-impaired person for locomotion," means that the wheelchair was originally designed and manufactured solely for use for mobility by a person with a disability. This term doesn't include the aftermarket retrofit of a motorized unit to make it usable by a person with a disability. "Suitable for use in an indoor pedestrian area" means usable inside a home, mall, courthouse, or other indoor pedestrian area. Figures 5 through 9 show some examples of devices that are wheelchairs and one that is not.



Figure 5.



Figure 6.

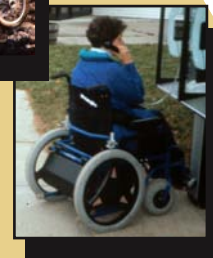

Figure 7.



Figure 8.

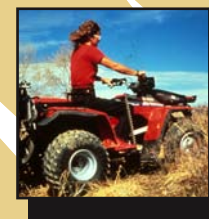

Figure 9.

Figures 5 to 9—Although figures 5 to 8 show wheelchairs, figure 9 shows a device that is not a wheelchair. Many wheelchairs look different from those shown. The only sure way to determine if a device is a wheelchair is to answer the two key questions described in the text.

To determine whether a device meets the definition of a wheelchair, evaluate it against the two sections of the definition. Ask yourself the following questions:

**1**—Was the device designed solely for mobility by a person with a disability?

If **no**, the device doesn't meet the definition and doesn't qualify for use as a wheelchair.

If **yes**, ask the second question:

**2**—Is it suitable for use in an indoor pedestrian area?

Consider whether it could be used in a mall, courthouse, or similar area without the security personnel directing the user to leave.

If **no**, the device doesn't meet the definition and doesn't qualify for use as a wheelchair.

If the answer to both questions is **yes**, the device meets the definition of a wheelchair and can be used wherever foot travel is permitted.

A person whose disability requires use of a wheelchair or assistive device may use a wheelchair that meets the definition above anywhere foot travel is permitted, in accordance with Title V, Section 507c, of the ADA (36 CFR 212.1) and the Forest Service Manual 2353.05. Wheelchairs or assistive devices, including battery-powered wheelchairs, aren't categorized as motorized vehicles or mechanical devices.

## Transition Plans

Since the 1968 passage of the ABA, facilities designed, built, bought, rented, altered, or leased by, for, or on behalf of a Federal agency are required to be accessible. Unfortunately, some Federal facilities are not yet accessible.

To correct this problem, in the early 1990s the Forest Service called for all units to complete transition plans identifying the changes needed to make each facility accessible and the timeline for completing the changes. Funding to complete the transition plans was provided to the regions in 1991, 1992, and 1993.

The accessibility regulation for the programs of all USDA agencies, 7 CFR 15e, was finalized in December 1994. This regulation required transition plans to be completed by December 31, 1997. 7 CFR 15e Section 150 (d) ([http://www.access.gpo.gov/nara/cfr/waisidx\\_03/7cfr15e\\_03.html](http://www.access.gpo.gov/nara/cfr/waisidx_03/7cfr15e_03.html)) details the specific requirements for transition plans and their contents.

In 1998, under Public Law 105-359, Congress mandated an evaluation of accessibility to outdoor recreation on federally managed lands for both the United States Department of Agriculture and Department of the Interior agencies. The results of the independent study that

### TERMINOLOGY TIP—

#### ***Wheelchairs are not motor vehicles.***

36 CFR 212.1 defines a motor vehicle as any vehicle that is self-propelled, other than:

- A vehicle operated on rails.
- Any wheelchair or mobility device, including one that is battery powered, that is designed solely for

use by a mobility-impaired person for locomotion, and that is suitable for use in an indoor pedestrian area.

Wheelchairs that meet this legal definition may be used anywhere foot travel is allowed.

was published in June 2000 highlighted to Congress that many Forest Service and other Federal agency units still had not completed their transition plans. The attention resulting from the report increased the pressure on Federal agencies to get the plans completed. To keep units focused on completing this work, the Forest Service national budget direction each year since 2001 has included direction to the field to complete the transition plans.

*Program Accessibility: Existing Facilities* (7 CFR 15e Section 150) allows a program to be “viewed in its entirety” when accessibility is evaluated. However, a transition plan must be developed and implemented for any program that is not accessible because the facility housing the program is not accessible.

No standardized format has been provided for transition plans. Each region and some national forests developed their own transition plan format. Check with your agency’s accessibility coordinator, your regional recreation accessibility coordinator (RRAC) (<http://fsweb.mtdc.wo.fs.fed.us/toolbox/acc/documents/coord.htm>) or your region/station facilities program leader ([http://fsweb.wo.fs.fed.us/eng/documents/fac\\_leaders.htm](http://fsweb.wo.fs.fed.us/eng/documents/fac_leaders.htm)) to find out whether your local unit has developed a format. If not, request a sample of the formats used by other units. At a minimum, the transition plan must include:

- A list of obstacles to accessing the facility and program as identified in the accessibility evaluation survey
- A detailed description of the methods that will be used to provide accessibility
- The schedule for implementing the plan, including the actions that will be taken each year if the work takes more than a year

- The signature of the official responsible for implementation of the transition plan

Transition plans must be available to the public.

## Accessibility Evaluation Surveys

An accessibility evaluation survey is the first step in developing a transition plan. During the survey, each portion of a structure is compared to the accessibility standards, and compliance and deficiencies are recorded.

For example, doorways must be checked to see whether they have at least 32 inches (815 millimeters) of clear width. Measure clearance when a swinging door is open 90 degrees and when the door is fully opened for other types of doors. Stretch the measuring tape from the face of the open door to the nearest portion of the doorframe or latch mechanism on the latch side (figure 10).



Figure 10—All doorways must have a minimum of 32 inches (813 millimeters) clear width.

Two checklists on the Internet can be used as accessibility evaluation guides for facilities: the *Uniform Federal Accessibility Standards Checklist* (<http://www.access-board.gov/ufas/UFASchecklist.txt>) and the *ADA Accessibility Guidelines Checklist for Buildings and Facilities* (<http://www.access-board.gov/adaag/checklist/a16.html>). However, your local unit may have developed

checklists that will better match your facilities. Check with your agency's accessibility coordinator, your regional recreation accessibility coordinator (<http://fsweb.mtdc.wo.fs.fed.us/toolbox/acc/documents/coord.htm>), or your region/station facilities program leader ([http://fsweb.wo.fs.fed.us/eng/documents/fac\\_leaders.htm](http://fsweb.wo.fs.fed.us/eng/documents/fac_leaders.htm)) for more information.







# So Many Guidelines, So Little Time—Applying Accessibility Guidelines to Your Site

How did we end up with so many accessibility guidelines and standards? Which guidelines and standards apply to your site? The following information will demystify accessibility guidelines and standards.

## The History of Accessibility Guidelines

As explained in the previous chapter, accessibility laws have been enacted and updated since 1968. Here is a brief history of the guidelines for buildings:

- **American National Standards Institute (ANSI)—1969 to 1980.** The first accessibility guidelines used by Federal agencies under the Architectural Barriers Act (ABA).
- **General Services Administration Accessibility Guidelines—1980 to 1984.** The General Services Administration (GSA) developed its own set of guidelines for all buildings other than those of the Department of Housing and Urban Development, the Department of Defense, or the U.S. Postal Service. Those agencies developed their own guidelines.
- **Uniform Federal Accessibility Standards (UFAS)—1984 to 2006.** These standards updated and expanded the General Services Administration Accessibility Guidelines. The standards were adopted under the ABA, and apply to all federally funded facilities, unless there is a higher standard of accessibility for that type of structure required by other legal standards or guidelines.
- **Americans with Disabilities Act Accessibility Guidelines (ADAAG)—1991 to 2004.** The ADAAG explains how to apply the Americans with Disabilities Act (ADA) of 1990 in the built environment. These guidelines apply to services provided by State and local governments, and public accommodations, such as motels and hotels.

## Current Accessibility Guidelines

In 2004, the Architectural and Transportation Barriers Compliance Board (Access Board) finished updating and merging the UFAS and ADA accessibility guidelines. The combined *Americans with Disabilities Act/Architectural Barriers Act Accessibility Guidelines* are available at: <http://www.access-board.gov/ada-aba/>.

These guidelines apply to all Federal, State, and local government facilities and to public accommodations. In November 2005, the General Services Administration, the standard-setting agency for Forest Service facilities, adopted the ABA portion of the combined guidelines. The Architectural Barriers Act Accessibility Standard (ABAAS) is the name given by the GSA to the standards the Forest Service must follow. The ABAAS became effective on May 8, 2006.

*Chapter 1:* Explains when, where, and how many of each component must be accessible (scoping) for all entities under the ADA, including State and local government services and public accommodations.

*Chapter 2:* Explains when, where, and how many of each component must be accessible (scoping) for all entities under the ABA, including facilities that are built, bought, rented, or leased by, for, or on behalf of a Federal agency. The numbering for these scoping provisions begins with the letter *F* as a friendly reminder that they apply to federally related facilities.

*Chapters 3 through 10:* These chapters contain technical provisions that apply to entities governed by both the ADA and the ABA.

The Access Board is an independent Federal agency devoted to accessibility for people with disabilities. It operates with about 30 staff and a governing board of representatives from Federal departments and public members appointed by the President. Key responsibilities of the board include:

- Developing and maintaining accessibility requirements for the built environment, transit vehicles, telecommunications equipment, and for electronic and information technology
- Providing technical assistance and training on these guidelines and standards
- Enforcing accessibility standards for federally funded facilities

The Access Board developed the guidelines to serve as the basis for enforceable standards issued by four standard-setting agencies: the Department of Defense (DOD), the General Services Administration (GSA), the Department of Housing and Urban Development (HUD), and the U.S. Postal Service (USPS). The USDA and the Forest Service follow standards (the ABAAS) set by the GSA.

12

The Forest Service guidelines for outdoor elements and trails don't change an agency's responsibility to comply with the ABAAS. Agencies must comply with the ABAAS when designing or constructing any facility or component addressed by those standards. Drinking fountains, plumbed toilet facilities, parking lots and spaces, and cabins are among the components covered by the ABAAS.

## Accessibility Guidelines Under Development

The Access Board (<http://www.access-board.gov/>) is developing accessibility guidelines that will apply to special situations, such as passenger vessels, outdoor developed areas, and public rights-of-way. They will be chapters of the ABAAS when they become final.

The **public rights-of-way accessibility guidelines** (<http://www.access-board.gov/news/prowac/>) will cover access to sidewalks and streets, including cross-

walks, curb ramps, street furnishings, parking, and other components of public rights-of-way. These draft guidelines were proposed and submitted for comment during 2002.

## Guidelines for the Outdoor Environment

All of the guidelines and standards listed above, including the ABAAS, focus on facilities in highly developed areas, such as cities, towns, and major tourist attractions. With the exception of boating facilities and fishing piers and platforms, they don't provide direction for the construction or renovation of outdoor developed recreation areas and trails managed for hiker or pedestrian use.

In 1993, the Forest Service developed *Universal Access to Outdoor Recreation: A Design Guide* (called the Design Guide), which integrated the principles of universal design into all recreation settings. The Access Board also recognized the need for guidelines focused on outdoor recreation and formed a regulatory negotiation committee in 1997 to address the issue. The Forest Service was among the agencies and interest groups represented on the committee. The committee developed draft accessibility guidelines for outdoor developed areas. However, because the Access Board's regulatory negotiation committee's draft guidelines applied to all private, State, and Federal outdoor recreation areas, the rule-making process was delayed. While the draft guidelines were similar to the Forest Service guidelines in the Design Guide, the approach for incorporating accessibility into the outdoor environment differed significantly. In 2000, the Forest Service suspended use of the design guide because it tied accessibility to levels of development identified in the Recreation Opportunity Spectrum.

Because the Access Board's draft guidelines for outdoor recreation have not yet completed the rule-making process, the Forest Service has developed its own guide-



lines based on the Access Board's draft guidelines. These new agency accessibility guidelines for outdoor recreation and trails have completed the required directives process, including public comment. The Forest Service continues to work with the Access Board and other Federal agencies to complete national guidelines for outdoor recreation and trails that will apply to all Federal land management agencies.

When the Access Board finalizes its accessibility guidelines for outdoor developed areas, the Forest Service will revise the Forest Service Outdoor Recreation Accessibility Guidelines and the Forest Service Trail Accessibility Guidelines to incorporate the Access Board's standards, where those provisions are a higher standard, as supplemented by the Forest Service. The supplementation will ensure the agency's application of equivalent or higher guidelines and universal design, as well as consistent use of agency terminology and processes.

The **Forest Service Outdoor Recreation Accessibility Guidelines** (FSORAG) apply to newly constructed and

reconstructed camping facilities, picnic areas, beach access, outdoor recreation access routes (ORARs), and other constructed recreation features, such as picnic tables, benches, trash and recycling containers, viewing areas at overlooks, telescopes or periscopes, storage for assistive devices, remote area pit toilets, warming huts, outdoor rinsing showers, and so forth. These guidelines apply only within National Forest System boundaries. The entire text of the FSORAG is in the *Resources* section at the end of this guidebook.

The **Forest Service Trail Accessibility Guidelines** (FSTAG) apply to new or altered trails that are designed for hiker and pedestrian use and that connect either directly to a trailhead or to an accessible trail. These guidelines apply only within National Forest System boundaries. The entire text of the FSTAG is in the *Resources* section at the end of this guidebook.

Table 1 is a simplified overview of the application of the ABAAS, FSORAG, and FSTAG.



Table 1—Accessibility guidelines quick guide (which guideline applies where).

ABA Accessibility Standards	Apply only within National Forest System boundaries	
	FSORAG	FSTAG
<b>BUILDINGS, BOATING AND FISHING</b>	<b>DEVELOPED RECREATION SITE FEATURES</b>	<b>HIKER/PEDESTRIAN TRAILS</b>
<p><b>All buildings, including:</b></p> <ul style="list-style-type: none"> <li>• Administrative offices</li> <li>• Residences</li> <li>• Crew quarters</li> <li>• Visitor centers</li> <li>• Entrance stations</li> <li>• Parking lots</li> </ul> <p><b>And including components, such as:</b></p> <ul style="list-style-type: none"> <li>• Restrooms with and without running water</li> <li>• Workstations</li> <li>• Doors</li> <li>• Operating controls (door handles, faucets controls, thermostats, and so forth)</li> </ul> <p><b>Boating and fishing facilities, including:</b></p> <ul style="list-style-type: none"> <li>• Boating facilities</li> <li>• Docks</li> <li>• Fishing piers and platforms</li> </ul>	<p><b>New or reconstructed:</b></p> <ul style="list-style-type: none"> <li>• Picnic areas</li> <li>• Fire rings</li> <li>• Grills</li> <li>• Wood stoves</li> <li>• Benches</li> <li>• Outdoor recreation access routes</li> <li>• Camping units (eating and cooking areas, parking spurs, platforms, tent pads)</li> <li>• Campground utility connections</li> <li>• Water hydrants and drinking fountains</li> <li>• Outdoor rinsing showers</li> <li>• Remote-area pit toilets</li> <li>• Trash/recycling containers</li> <li>• Viewing areas and overlooks</li> <li>• Telescopes and periscopes</li> <li>• Mobility device storage</li> <li>• Warming huts</li> </ul>	<p><b>New or altered trails that are:</b></p> <ul style="list-style-type: none"> <li>• Designed for hiker/pedestrian use and</li> <li>• That connect either directly to a trailhead or</li> <li>• Connect to a currently accessible trail</li> </ul>

### What If the Guidelines Appear to Conflict With Each Other?

It may appear that some accessibility guidelines conflict with other guidelines or codes, or with the realities of the outdoor environment. Railings must be high enough to protect visitors from a dropoff, but railings that high might limit the viewing opportunity for a person using a wheelchair, so which requirement takes priority? Trash receptacles are supposed to be accessible so that everyone can use them, but then how do we keep bears out? Hand pumps are vital to drawing water in campgrounds

where the water system isn't pressurized, but operating the long handle of the traditional pump requires more force and a longer reach than allowed by accessibility requirements. Roads that have restrictions or closures to use by motorized vehicles may be open to foot travel, so how can a road be gated or bermed to keep out vehicles but still allow access by a person using a wheelchair? When you are faced with these types of situations, stop and think carefully about the issues. The solution always



comes back to ensuring safety, abiding by the regulations, and doing so in a manner that includes the needs of all people.

**Railings and Safety:** Accessibility never supersedes the requirements for safety. This issue most commonly arises at overlook areas, on viewing structures, and in similar locations. For safety, the International Building Code (IBC) (<http://www.iccsafe.org/>) section 1003.2.12 contains requirements for guardrail height and the spacing of rails at dropoffs. This requirement provides opportunities for creative design and for managers and designers to think seriously about the level of development that is appropriate for the setting. The creativity challenge is to provide safety when designing the railing or structure adjacent to the dropoff, while maximizing viewing opportunities. Methods of solving this challenge are discussed in *Viewing Areas at Overlooks*.



**TERMINOLOGY TIP—**

***What's the difference between a guardrail, a handrail, and a grab bar?***

The following explanations of terms are based on the use of these terms in the International Building Code and the Architectural Barriers Act Accessibility Standards. Keeping these explanations in mind and using them as they are used in the codes, standards, and guidelines will help everyone communicate more effectively.

**Guardrails** protect people from dropoffs higher than 30 inches (760 millimeters). Guardrails must be at least 42 inches (1,065 millimeters) high. If the guardrail has openings that are less than 34 inches (865 millimeters) above the walking surface, they must be small enough to prevent a 4-inch (100-millimeter) sphere from passing through them (figure 11).

*Continued* ➤

Requirements for guardrails are detailed in the International Building Code section 1003.2.12.

**Handrails** provide a steady support for persons who are going up or down stairs or inclines. Handrails must be between 34 inches (865 millimeters) and 38 inches (965 millimeters) above the walking surface and be easy to grip. Details about acceptable configurations for handrails are provided in the International Building Code section 1003.3.3.11 and in the Architectural Barriers Act Accessibility Standards section 505.

**Grab bars** provide stability and allow people to use their arms to help them move short distances. The most common location for grab bars is in restrooms. The required locations of grab bars are explained in the Architectural Barriers Act Accessibility Standards chapter 6. Details about grab bar configuration and attachment are provided in the Architectural Barriers Act Accessibility Standards section 609 and in the International Building Code chapter 11.

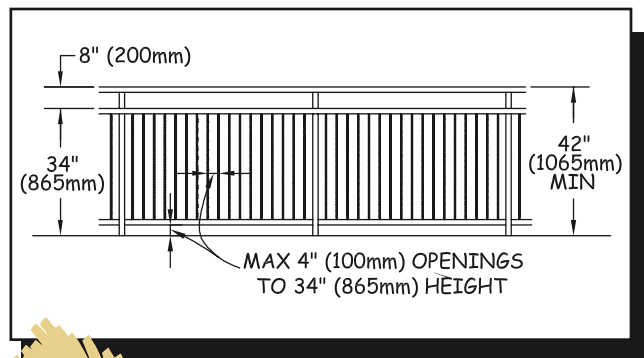

Figure 11—Dimensions required for guardrails.

Reconsidering the **level of development** at a site may be another way to balance safety and accessibility issues. It may not always be appropriate to provide paved paths and interpretive signs. When signs indicate a scenic

viewpoint and a paved pathway begins at the parking lot, visitors are likely to stop, pile out of their vehicle, and head down that pathway, often with the children running ahead. Because of the high level of development at the entrance to the pathway, visitors expect that the viewpoint will have a similar high level of development, including safety features. Development should be consistent at both ends of the pathway.

If the area isn't developed, such as a waterfall in the forest with no signs or constructed trail to it, it may not be appropriate to develop a viewpoint. Some scenic areas should remain natural so that people have the opportunity of adventure and solitude. The safety and accessibility requirements only apply when constructed features are added to the setting.

16

Safety is also the primary issue when it comes to the accessibility of **trash receptacles**. In bear country, trash and recycling containers must be designed to keep bears out to minimize contacts between bears and humans. Operating controls for these containers require more force than is allowed for accessible operation. Until bear-resistant trash and recycling containers are available that comply with the technical provision for accessible operating controls, recreation areas where bears and other large animals pose a risk to humans are exempt from this provision. Incidentally, dumpsters—the big containers that are mechanically lifted and tipped to empty into commercial garbage trucks—are exempted from accessibility guidelines. More information about trash receptacles is in *Trash, Recycling, and Other Essential Containers*.

**Handpumps** also have been a concern (figure 12). Because of the piston-like pump mechanism, handpumps require a long reach. As the depth of the well increases, so does the force necessary to draw water, so most hand pumps require a force greater than 5 pounds (2.2 newtons) to operate. The good news is that an accessible handpump has now been developed and is available for



Figure 12—Others used to have to do the pumping.

purchase. For shallower wells, this pump can draw the water while remaining in full compliance with the grasping, turning, and pressure restrictions of the accessibility guidelines (figure 13). More information about the new



Figure 13—Now the choice of who does the pumping is up to the campers.

pump is available at: <http://www.fs.fed.us/t-d/programs/eng/handpump.htm> (Username: t-d Password: t-d).

For wells with a static water depth of 50 feet (12 meters) or less, use the accessible handpump for all new installations. Accessible pumps for deeper wells are being developed and should be used when they become available.

When **gates, barriers, or berms** are installed on a road to close it to motorized traffic but foot travel is encouraged beyond the closure, people in wheelchairs must be able to get behind the closure, as required by Section 504 of the Rehabilitation Act of 1973. As explained in Program Accessibility, a wheelchair is permitted anywhere foot travel is permitted.

When foot travel is encouraged beyond a closure, the USDA Office of General Counsel has determined that a minimum of 32 inches (815 millimeters) of clear passage must be provided around the gate, berm, or other restrictive device to ensure that a person who uses a wheelchair can participate in the opportunity behind the restriction. This width is the minimum required for a door under the ABAAS. Various methods can provide passage around a restrictive device (figures 14, 15, and 16).

Indications that foot travel has been encouraged include:

- Destination signing
- A pedestrian recreation symbol without a slash
- A Forest Service map that highlights an opportunity behind the closure
- A transportation management objective or recreation management objective stating that pedestrian use is encouraged

In areas where foot travel isn't encouraged, but occasional pedestrian use is allowed before and after installation of the restriction device, individuals who use wheelchairs may raise a concern about access at those restriction devices. In such cases, we must work with the individuals to provide access around the barrier.



Figure 14.

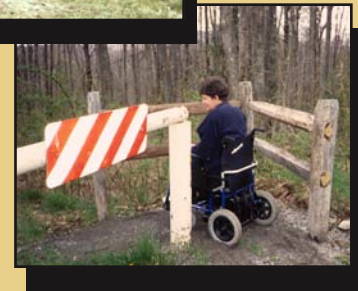

Figure 15.



Figure 16.

Figures 14, 15, and 16—Three ways to get around a road closure gate



# A

## All the Rest—Other Important Tools for Accessible Recreation

The following tools work together with the accessibility guidelines when accessible recreation facilities and programs are being developed and managed.

### Built Environment Image Guide

The *Built Environment Image Guide* (BEIG) (<http://www.fs.fed.us/recreation/programs/beig/>) provides guidance for improving the image, esthetics, sustainability, and overall quality of the Forest Service's built environment. It emphasizes key elements to showcase the Forest Service's national identity and an image of quality and service. Within eight geographically defined architectural character types, designs project the overall Forest Service image while echoing local values, heritage, and culture. The BEIG's use will lead to an integrated approach to planning and design, including early collaboration among planners, designers, specialists, managers, and maintenance personnel.

Buildings and other constructed features will:

- Fit on the land
- Reflect sensitive site planning and a concern for natural processes
- Harmonize with the local landscape and climate.
- Incorporate the principles of sustainability as an integral part of their architectural character
- Be accessible
- Be durable and low maintenance

The BEIG specifically requires use of universal design principles and points out that if universal design principles are applied to a site or facility design from the outset, they seldom, if ever, have any obvious effect on architectural character. When the principles of universal design are skillfully executed, facilities fit seamlessly within the natural and social environments.

### Recreation Opportunity Spectrum

Recreation Opportunity Spectrum (ROS) classifications provide guidance on the:

- Amount of development that is acceptable at any given site
- Amount of deviation from the site's natural characteristics that is appropriate during development
- Types of materials that are appropriate for the setting
- Typical recreation activities in each setting classification (figure 17)



Figure 17—This free climber appears to enjoy the challenge, self-reliance, and independence characteristic of semi-primitive and primitive recreation opportunity spectrum settings.

The spectrum identifies characteristics of Urban, Rural, Routed Natural, Semi-Primitive Motorized, Semi-Primitive Non-Motorized, and Primitive areas. Some units also include a Routed Modified classification. Maps should be available at district or supervisor's offices showing the ROS classification for the Forest Service system lands administered by that unit. ROS classifications do not determine accessibility requirements, but should be taken



into account when designing site improvements. For instance, improvements in primitive and semi-primitive settings may sometimes be needed for resource protection. In roaded natural, rural, and urban settings, improvements commonly are provided for visitor comfort and convenience. More information about the ROS is available to Forest Service and Bureau of Land Management employees at: <http://fsweb.wo.fs.fed.us/eng/facilities/recopp.btm>.

### Wilderness Access Decision Tool

Details and implementation guidance for applying Title V Section 507c, the one section of the Americans with Disabilities Act that applies to Federal agencies and to the programs and facilities on federally managed lands can be found at: [http://carbart.wilderness.net/docs/wild\\_access\\_decision\\_tool.pdf](http://carbart.wilderness.net/docs/wild_access_decision_tool.pdf). This decision matrix is designed to assist Federal managers of wilderness areas in making appropriate, objective, and consistent decisions meeting the legal requirement to provide equal opportunity for all individuals, while ensuring there will be no fundamental change to the wilderness experience for all individuals, in accordance with the 1964 Wilderness Act.

### Appalachian Trail Conservancy's *Backcountry Sanitation Manual*

This comprehensive manual explains the basic issues of remote area sanitation, including health, esthetics, and regulations, but it focuses on the construction and maintenance of moldering and composting toilets, and includes a case study and design plans. The *Backcountry Sanitation Manual* (<http://www.appalachiantrail.org/>

[protect/steward/sanman.html](http://protect/steward/sanman.html)) is a cooperative project of the Green Mountain Club and the Appalachian Trail Conference.

*“Resolving problems of backcountry sanitation is a continuous challenge for trail clubs and land managers. This manual was created in the belief that all remote recreation areas will benefit from an expanded discussion of backcountry sanitation.”*—Pete Antos-Ketcham, Education

*Coordinator/Facilities Manager, Green Mountain Club*

### Accessibility Guidebook for Outfitters/ Guides Operating on Public Lands

This guidebook provides a framework to help outfitters and guides who operate under a special-use permit from the Forest Service better serve all visitors (figure 18). The guidebook addresses basic facility accessibility

19



Figure 18—Outfitters and guides provide the logistics and support for visitors to enjoy a wide range of opportunities on National Forests, including fishing.

issues, but focuses primarily on program and activity accessibility. Outfitters and guides who operate businesses on public lands are governed by the ADA because they are providing public accommodations and are also governed by Section 504 of the Rehabilitation Act because they are operating under special-use permits from Federal agencies. The guidebook identifies legal requirements and provides guidelines, suggestions, and practical tips for complying with both the ADA and Section 504 of the Rehabilitation Act while providing high-quality services. The guidebook is available at: <http://www.fs.fed.us/recreation/programs/accessibility/>.

## Accessibility Guidebook for Ski Areas Operating on Public Lands

20

This guidebook provides a framework to help ski areas operating under special-use permits from the Forest Service better serve all visitors (figure 19). The guidebook addresses facility and program accessibility. Ski areas located on public lands are governed by the ADA because they are providing public accommodations and also are governed by Section 504 of the Rehabilitation Act and related regulations, because they are operating under special-use permits from a Federal agency. The



Figure 19—Ski areas that operate on public land must provide equal opportunity to their services.

guidebook provides the legal mandates, suggestions, and practical tips for complying with laws and regulations, while providing high-quality services. The guidebook is available at: <http://www.fs.fed.us/recreation/programs/accessibility/>.

## Cooperative Publications

The Federal Highway Administration is cooperating with the Forest Service to provide Forest Service publications and videos to the public. Many publications are available at: <http://www.fhwa.dot.gov/environment/fspubs/index.htm> in HTML and PDF (Acrobat) formats. Paper copies can be ordered at: <http://www.fhwa.dot.gov/environment/rectrails/trailpub.htm>.

## Standard Forest Service National Trail Specifications

Engineering Management Publication EM-7720-103, *Standard Specifications for Construction and Maintenance of Trails*, provides a uniform set of specifications for contracted trail work throughout the Forest Service. Although these specifications do not address accessibility, they can be used in conjunction with the FSTAG. The publication is available at: <http://www.fs.fed.us/database/acad/dev/trails/trails.htm>.

## Trail Construction and Maintenance Notebook

The Missoula Technology and Development Center's Trail Construction and Maintenance Notebook contains

basic trail construction and maintenance information, presented in an easy-to-understand fashion. It is available at: <http://www.fbwa.dot.gov/environment/fspubs/00232839/> and at: <http://www.fs.fed.us/eng/pubs/htmlpubs/btm04232825/>.

Although this publication doesn't address accessibility, it is an important tool used during trail construction and planning. It can be used in conjunction with the FSTAG.

A new version of the *Trail Construction and Maintenance Notebook* will be printed during 2006.

## Sidewalks and Trails

The Federal Highway Administration has published *Designing Sidewalks and Trails for Access*, a two-part report on pedestrian accessibility:

**Part 1:** *Review of Existing Guidelines and Practices* is available in both HTML and PDF formats at: <http://www.fbwa.dot.gov/environment/sidewalks/index.htm>. Part 1 lays out the history and practices of applying accessibility concepts to sidewalks and pedestrian trails.

**Part 2:** *Best Practices Design Guide* is available in both HTML and PDF formats at: <http://www.fbwa.dot.gov/environment/sidewalk2/index.htm>. Part 2 provides recommendations on how to design sidewalks, street crossings, intersections, shared-use paths, and recreational pedestrian trails.

## Equestrian Design Guidelines for Trails, Trailheads, and Campgrounds

A new guidebook for equestrian facility design is scheduled for completion in 2006. This comprehensive technical resource guide will detail those elements of planning, design, and construction that are specific to equestrian trails, trailheads, and campgrounds.

## The Facilities Toolbox

The *Facilities Toolbox* is an interactive, internal Forest Service facility management Web site designed to help line officers and their staffs manage facilities effectively. The toolbox focuses on issues at administrative sites, but also contains topics such as *Accessibility, Partnerships, Recreation Fee Program, Historic Facilities, and Water and Wastewater*. Forest Service and Bureau of Land Management employees can access this Web site on their internal computer networks at: <http://fsweb.mtdc.wo.fs.fed.us/toolbox/>.

## Infra

Infra (<http://infra.wo.fs.fed.us/infra/>) is the Forest Service corporate integrated data management tool developed for the purposes of inventory, asset management, and upward reporting of information concerning constructed features, including their associated financial data. Infra contains data on the accessibility status of constructed features and data on annual and deferred maintenance costs associated with accessibility requirements. The developed recreation area data entry forms have fields to enter information concerning the status of accessibility under the *site costs* tab and also under the *features* tab. These data must be updated annually.

## Recreation & Heritage Resources Integrated Business Systems

The *Meaningful Measures* recreation resources management system has recently become the *Recreation & Heritage Resources Integrated Business Systems* (<http://www.fs.fed.us/r3/measures/>). This recreation resources management system identifies customer standards the Forest Service expects to provide across all recreation and heritage resources program areas. Standards form the baseline for estimating the total cost for quality visitor opportunities and services. Compliance with the accessibility guidelines (figure 20) is an important quality measure within the national standards for developed sites under the responsiveness key measure. The Infra database houses recreation information including inventory, operation and maintenance costs, recreation-use data, and information on accessibility. The database is used to implement the Recreation & Heritage Resources Integrated Business Systems.

22



Figure 20—The perfect photo spot—a spectacular view and the right mix of resource protection, site development, and accessibility.

## Deferred Maintenance

Accessibility requirements must be met just as other building codes must be met. The costs for any needed accessibility improvements should be included in the Infra deferred maintenance figure. These costs are categorized as deferred maintenance because the work already should have been completed to comply with the ABA.

How and when the costs are included in the deferred maintenance figure depends on the transition plan for that facility. If transition plans have not been completed, the cost to complete them is included in the deferred maintenance figure because they were due for completion before the current fiscal year. The transition plan process (per 7 CFR 15e, section 150) is as follows:

- Evaluate the facility.
- Record improvements needed to meet accessibility standards.
- Develop the transition plan, including:
  - Items to be improved
  - When the improvements are scheduled if the improvements will take more than 1 year to complete

When the transition plan is completed and approved, the costs to implement accessibility code improvements are included in the deferred maintenance figure. If the transition plan will take more than 1 year to complete, costs for actions scheduled for the current year are included in the deferred maintenance figure. Costs for actions that are past due also are included in the deferred maintenance figure. Costs for actions scheduled for future years aren't added to the current year's deferred maintenance figure. They are added to the deferred maintenance figure in the year they are scheduled for completion. As work is completed, it should be shown as an accomplishment in Infra for that fiscal year.



## Construction and Maintenance Practices

Even the best universal design can be ruined, often unintentionally, by construction or maintenance practices that change accessible design features into barriers. Construction engineering and inspection personnel must have a thorough understanding of the design intent and of accessibility issues or they must check with the designer before allowing any deviations from the design. For example, field changes such as increasing the slope on a walkway to reduce the cost of asphalt paving or increasing the drop at an exterior door threshold to reduce issues with driving rain can make the entire project inaccessible.



### CONSTRUCTION TIP— *Avoiding unintended consequences*

Consider accessibility when construction is in progress. Any change order intended to solve one problem could create another. For example, standard speed humps can slow speeding traffic in a campground, but they can also become barriers if the main pedestrian access route through the campground is the roadway. Speed humps can be staggered to block only one lane at a time or limited to the center of the road, leaving 32 inches (815 millimeters) of clear passage at each side. Both of these approaches will slow traffic without blocking access.

Maintenance and operations activities can help or hinder accessibility. When maintenance personnel are being trained, include information on accessibility. When employees understand how their work can affect accessibility, they can look for ways to improve accessibility. For example, a chair or garbage receptacle beside the door of an accessible restroom stall will render the stall inaccessible if it prevents the door from opening fully. Picnic tables that are fastened to

the floor of a picnic shelter to prevent theft but that aren't spaced far enough apart will be impossible for some people to use. When gravel walkway material is allowed to erode away from the entrance of a campground restroom, the restroom soon will become inaccessible.

Maintenance also can be an opportunity to improve accessibility. Over time, a series of small changes can make a big difference.



### MAINTENANCE TIP— *Improving accessibility through maintenance*

Improved accessibility doesn't always mean new construction or major renovation. Maintenance and routine service present many opportunities to improve accessibility.

An **accessible surface** is firm and stable. Use caution with the size and depth of gravel when maintaining unpaved surfaces. Generally, smaller gravel with some fine material can be compacted to a firmer surface than larger gravel or gravel that is all the same size. Depending on the surfacing material, mixing in some soil stabilizer might provide an accessible, natural-appearing surface.

#### **Practical Approach—The surface is probably firm and stable if ruts are not left by:**

- Someone riding a bicycle with narrow tires
- Someone pushing a 3-year-old in a folding stroller with small plastic wheels

On paved **parking lots**, designating the required accessible spaces is relatively easy when repainting the parking lot stripes, especially right after the lot

*Continued* ➤

has been seal-coated. Designating accessible parking spaces on gravel lots is even easier. All you need is a sign and probably some parking bumpers to generally define the width of an accessible parking space without obstructing the access aisle. Ensure that signs and curb cuts for ramps are located appropriately—next to, not in the parking space or access aisle.

**Building entries** must be within ¼ inch (6.4 millimeters) of being flush with the grade of the outside access route and have a beveled doorsill that isn't more than ½ inch (13 millimeters) high. Sometimes it's fairly easy to add surfacing material, shim up the deck or porch boards, or use asphalt or concrete to bring the access route up to the building floor.

The surface at the base of **water hydrants** at recreation areas must be firm and stable with a 60-inch (1,525-millimeter) turning radius. Consider building a wood or concrete surface around hydrants if a soil

or gravel surface can't be made firm and stable. If you don't have funding for a major site renovation, you can repair the area around a few hydrants at a time.

When **operating controls** need replacing, think about accessibility. To comply with accessibility guidelines, all controls must be operable without pinching, grasping, or twisting the wrist and with no more than 5 pounds (2.2 newtons) of pressure. When accessible parts are ordered, consider ordering extra parts to keep on hand for future replacements.

**Practical Approach—If you can operate the control with a closed fist and with less than 5 pounds (2.2 newtons) of pressure, the control is accessible.** Three ways to provide accessible controls are shown in figures 21, 22, and 23.

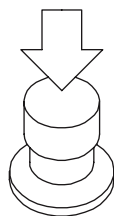

Figure21.

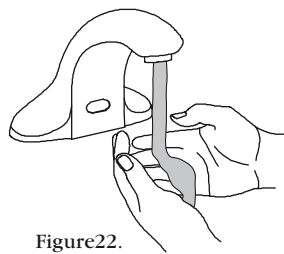

Figure22.

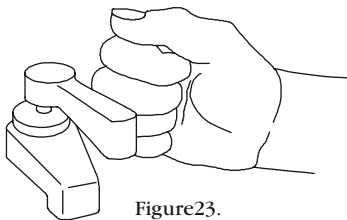

Figure23.

Figures 21, 22, and 23—Examples of accessible operating controls.



# Designing Access Into the Outdoor Environment

This chapter explains how to incorporate the Forest Service Outdoor Recreation Accessibility Guidelines (FSORAG) and Forest Service Trail Accessibility Guidelines (FSTAG) into the outdoor recreation environment.

Suppose you are assigned a project to reconstruct a picnic area or campground, or to design a trail. Based on information from the previous chapters, you know that you'll be using FSORAG and FSTAG rather than *Architectural Barriers Act Accessibility Standards (ABAAS)*. As you read through the FSORAG and FSTAG, however, you may have questions about how to apply all the conditions for departure, provisions, and exceptions to the provisions of the guidelines. The purpose of this chapter is to explain how designers should apply the guidelines and to help them understand the rationale behind each of the provisions.

## Terminology

Some terms used in the FSTAG and FSORAG may not be familiar. The terms include:

**Conditions for departure** from the guidelines are circumstances found in natural environments that may make compliance with the provisions difficult.

**Exceptions** to the provisions are allowed under certain circumstances and are identified in paragraphs labeled "Exception" in the FSTAG and FSORAG.

**Scoping** means figuring out when, how much, and where the guidelines apply.

**Technical provisions** state what is required to be done.

The following terms describe construction and maintenance work:

**Construction** is building a new trail, recreation site, or facility where there was none before.

An **alteration** is a change in the original purpose, intent, or function for which the trail, recreation site, or facility was designed.

**Maintenance** is routine or periodic repair of existing trails, recreation sites, or facilities. Maintenance doesn't change the original purpose, intent, or function of a facility. Maintenance work isn't covered by the FSORAG or FSTAG. Maintenance includes but isn't limited to:

- Repairing or replacing deteriorated, damaged, or vandalized trails, facilities, or components. Examples include repainting, removing graffiti, and repairing or replacing components of facilities with new components similar to the original ones. Components include sections of bridges or boardwalks, signs, fencing and railings, siding, windows, and roofing.
- Removing debris and vegetation, such as fallen trees or broken branches; clearing encroaching vegetation from trails, pathways, lawns, or landscaped areas; and removing rock slides.
- Maintaining trail tread and access routes, including filling ruts, reshaping a trail bed, replacing or reshaping surfacing material, repairing washouts, installing riprap to retain cut and fill slopes, constructing retaining walls or cribbing to support trail tread, and repairing concrete or asphalt paving.
- Performing erosion control and drainage work, such as replacing or installing drainage dips or culverts and realigning sections of trail to reduce erosion or avoid boggy areas.

While the FSORAG and FSTAG don't apply to maintenance, Forest Service policy is to improve accessibility wherever the opportunity arises. Where practicable and feasible, resource managers are encouraged to improve accessibility through maintenance and repair activities as explained in maintenance tip *Improving accessibility through maintenance*.

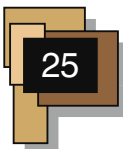

The term *reconstruction* isn't used in Federal accessibility guidelines or the FSORAG and FSTAG, even though it is frequently used in the recreation and trails communities. For the purposes of the FSORAG and FSTAG, actions are categorized as construction, alteration, or maintenance.

## The Purpose of the FSORAG and FSTAG

The FSORAG and FSTAG provide guidance for maximizing accessibility while recognizing and protecting natural settings—sometimes this is a real balancing act! Some basic assumptions:

- The FSORAG and FSTAG closely follow the draft document on outdoor recreation developed by a regulatory negotiations committee of the Architectural and Transportation Barriers Compliance Board (Access Board) and will be modified if necessary to conform to the final document, when it is complete.
- The FSORAG and FSTAG integrate the Forest Service policy of universal design.
- Accessibility is to be considered up front, not as an afterthought.

- All new construction and alterations will be as accessible as possible.
- Compliance with the FSORAG and FSTAG does not mean that all developed recreation areas and trails will be accessible to all persons with disabilities; in some locations, the natural environment will prevent full compliance with some of the technical provisions.

The FSORAG and FSTAG each include sections explaining when, where, and how much of the recreation area or trail is included (scoping), what has to comply with the guidelines, definitions of terms, and technical provisions defining the physical characteristics of accessible features such as width, height, slope, length, surface conditions, and so forth. The building blocks for accessible design are based mostly on wheelchair dimensions, clear space, maneuvering room, and reach ranges found in the ABAAS because the dimensions, multiple moving surface contact points, and wheels of a wheelchair are the most difficult to accommodate. If someone in a wheelchair can use an area, most other people can too.

Each section of the FSORAG is explained below in practical terms, followed by a similar explanation of the FSTAG.



# Applying the Forest Service Outdoor Recreation Accessibility Guidelines

The first step in applying the FSORAG is to know when and where compliance is required. Sections 1.0 *General* and 1.1 *Extent of Application* state that newly constructed and altered camping facilities, picnic areas, constructed features, beach access routes, and outdoor recreation access routes (ORARs) under Forest Service jurisdiction must comply with sections 1 through 6 of the FSORAG. Every bit of public land does not need to be developed, but if we build something, we need to build it for everybody (figure 24).



Figure 24—Universal design makes sense.

The FSORAG is based on the realities of the outdoor environment. It recognizes that accessibility isn't feasible everywhere because of the limitations imposed by natural terrain, existing vegetation, or other constraints. To ensure that the unique characteristics of the outdoor environment and recreation opportunity at a site aren't compromised or fundamentally altered, exceptions and deviations from some technical provisions are permitted where certain circumstances, called conditions for departure from the guidelines, apply. Conditions for

departure apply only where there is an exception detailed in the technical provision sections for a particular recreation feature.

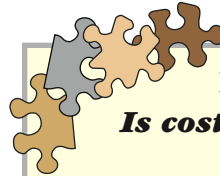

## BUDGET TIP—

### *Is cost an excuse?*

If making a new or renovated recreation area accessible adds to the cost, can we claim that it would be an “undue financial burden” and continue without making the area accessible?

No we can't. When a Federal agency, such as the Forest Service, is funding a project, cost cannot be used as the reason for failing to make the project accessible, unless the cost of making the project accessible would have a significant adverse impact on the agency's entire budget. Situations where this would apply are quite rare.

## Using the Conditions for Departure in the FSORAG

Although conditions for departure allow for exceptions and deviations due to limitations imposed by the environment, they are not a blanket exemption from the technical provisions. The deviations permitted by conditions for departure should only be used after all other design options to provide accessibility have been thoroughly explored. Deviations are permitted only where an exception is allowed for that particular feature and is needed in the specific area being designed. If a condition for departure exists only on part of the feature, the technical provision applies to the rest of the feature and all the technical provisions that are not affected by the condition for departure apply as well.



DESIGN TIP—

***Where do conditions for departure apply?***

A good way to get a handle on where a condition for departure applies and where it might not is to consider an example. A renovation project at San Antonio Campground in the Santa Fe National Forest in the Southwestern Region includes a walk-in camping unit where a portion of the outdoor recreation access route (ORAR) is located on extremely steep ground, and there's no way to relocate the ORAR to flatter land. The terrain makes it impossible to meet the technical provision for running slope without severe cuts or fills.

Using the definitions in the FSORAG, the project is an alteration. *Section 2.2 Slopes* of the FSORAG allows an exception from the slope requirement at existing recreation sites that are being altered, where a condition for departure exists. A review of *Section 1.1 Conditions for Departure* indicates that the condition for departure 2 applies to the section of the ORAR that is on steep ground because the cuts and fills necessary to meet the slope provision would substantially change the nature of the setting.

A deviation from the slope provision is permitted for the steep section of the ORAR. However, all other technical provisions for an ORAR such as width, surfacing, and cross slope, must be met. Where the terrain is flatter and the cuts and fills aren't an issue, the technical provision for slope must be met. The exception to the slope provision for the ORAR to this particular walk-in campsite doesn't apply to other campsites at this campground. The ORAR to each campsite must be examined individually to determine if a condition for departure exists that would permit an exception to any provision.

Four conditions for departure permit deviations from specific technical provisions where they are allowed by an exception. Examples are provided to explain the intent of the conditions for departure.

**1—Where compliance would cause substantial harm to cultural, historic, religious, or significant natural features or characteristics.**

Cultural features include areas such as archeological sites, burial grounds and cemeteries, traditional cultural properties, and tribal protected sites. Historical features are properties listed or eligible for listing on the National Register of Historic Places or other places of recognized historic value. Religious features are tribal sacred sites and other properties considered sacred by an organized religion. Significant natural features are objects such as a large boulder or rocky outcrop, body of water, or unique vegetation that are regarded as distinctive or important locally, regionally, or nationally (figure 25). Areas protected under Federal or State laws, such as habitat for threatened or endangered species or designated wetlands, also could be considered significant natural features.

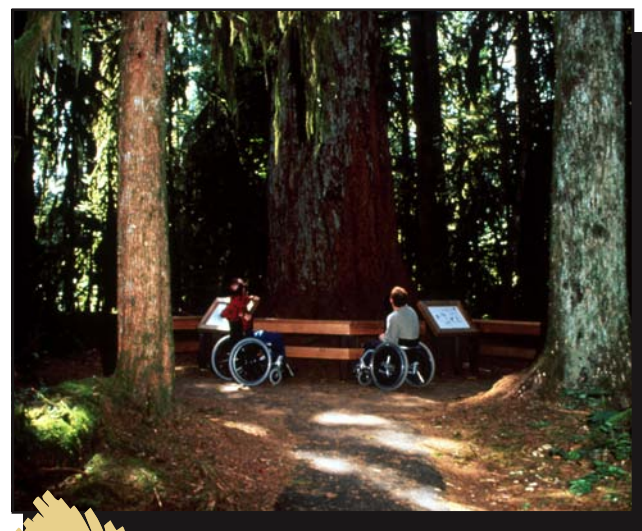
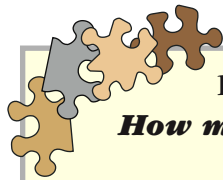

Figure 25—Properly developed recreation features don't harm significant natural vegetation.

If the significant feature would be directly or indirectly harmed in the process of providing accessibility, this condition for departure would apply. Consider only the additional impact of change necessary to provide accessibility. This condition for departure doesn't apply where substantial impact will result from construction of features that are not accessible and construction directly related to accessibility adds just a little more impact.



#### DESIGN TIP—

#### *How much is too much?*

The harm that is to be considered by this condition for departure is only the additional impact of increasing the size, relocating the recreation feature, or other change necessary to provide accessibility. For instance, there may be concern about the number of trees of an uncommon species being removed to make way for an accessible campsite because removal will cause substantial harm to a significant tree grove. This condition for departure wouldn't apply if 15 trees must be removed to make way for a campsite that is not accessible and only three more trees must be removed to provide for one that is. The majority of the proposed damage to the grove is due to construction of the campsite, not due to compliance with accessibility requirements. In this case, an alternate location should be selected for the campsite.

**2—Where compliance would substantially change the nature of the setting or the purpose of the facility or a portion of the facility, or would not be consistent with the applicable forest land and resource management plan for the area.**

Public lands provide a wide variety of recreational settings, from highly developed campgrounds with plenty of opportunities to relax with family and friends, to wilderness areas that appear unchanged from primeval times with opportunities to experience primitive and challenging conditions (figure 26). The FSORAG recognizes the value of a wide array of recreational opportunities by allowing exceptions where compliance with technical provisions would unacceptably change the



Figure 26—People who recreate in primitive areas may be looking for risk and challenge.

nature of recreation opportunities or conflict with the land and resource management plan for the area.

Campers in a primitive setting experience the outdoor environment in a nearly natural state, with limited or no development. These campers generally desire challenge and risk so they can use their outdoor survival skills. Use of manufactured building materials or engineered construction techniques to comply with accessibility requirements could destroy the natural or undeveloped nature of the setting. There is no requirement to use drastic measures to provide accessibility if doing so would unacceptably change the character of the setting and the recreation opportunity.



DESIGN TIP—

***Looking at the full range of issues***

Designers and managers need to examine the larger context and intent of the project to determine whether this condition for departure applies. The full range of management and design issues must be considered. Consideration of impacts should begin during planning and continue throughout all stages of design development.

Consider existing and desired levels of development and site modification as identified in ROS classifications, visitor expectations, customer service, and so forth. Take into account how the site will be used. Will it be a jumping-off point to a wilderness where campers bring lightweight, compact equipment, or will it be a social gathering place where visitors bring a good portion of their worldly possessions and expect to have a place to set them up?

This condition for departure would apply differently to a setting that has little or no human-influenced modifications than it would to a setting that has already been moderately or heavily modified, such as a developed recreation area.

**3—Where compliance would require construction methods or materials that are prohibited by Federal, State, or local law, other than State or local law whose sole purpose is to prohibit use by persons with disabilities.**

This condition for departure can be illustrated by example. For instance, use of mechanized equipment is prohibited in congressionally designated wilderness areas. If work necessary to comply with a technical provision can't be accomplished using handtools, this condition for departure will apply in wilderness areas.

This condition for departure may also apply in:

- Areas where imported materials, such as soil stabilizers, are prohibited to maintain the integrity of the natural ecosystem or historic resources.
- Designated wetlands or coastal areas where construction methods and materials are strictly limited.
- Areas where Federal statutes such as the Wilderness Act, the Endangered Species Act, or State and local laws impose restrictions to address environmental concerns.
- Areas where water crossings are restricted to safeguard aquatic features protected under Federal or State laws.

Local law has been included in this condition for departure to address situations where conservation or scenic easements or development programs have prohibited or restricted construction methods and practices. For example, where land is purchased from farms, certain use restrictions may prohibit importing surfacing materials.

On the other hand, under the Americans with Disabilities Act, State and local governments may not establish laws whose sole purpose is to prohibit use by people with disabilities. Therefore, such laws may not serve as a basis for deviation from the technical provisions in the FSORAG.

**4—Where compliance would be impractical due to terrain or prevailing construction practices.**

The phrase *would be impractical* in this condition for departure refers to something that isn't reasonable, rather than to something that is technically impractical. The intent of this condition for departure is that the effort and resources required to comply shouldn't be disproportionately high relative to the level of access established.



For example, when renovating an ORAR, compliance with the technical provisions, particularly those pertaining to running slope in areas of steep terrain, may require extensive cuts or fills that would be difficult to construct and maintain and that would cause drainage and erosion problems in highly susceptible soils. If compliance with the FSORAG requires techniques that clash with the natural drainage or existing soil, then the ORAR will be difficult—if not impossible—to maintain.

This condition also may apply where construction methods for particularly difficult terrain or an obstacle would require the use of equipment or methods other than that typically used in that setting. In an area where small equipment is normally used to minimize impact on a sensitive adjacent stream, blasting might be necessary to remove a rock outcrop. Because blasting typically would not be used in this situation, this condition for departure would apply. If the work could be done using small equipment, the condition for departure wouldn't apply.

This condition for departure isn't intended to exempt an area from the technical provisions simply because of preferred construction practice. A contractor may prefer to use a large mechanical roller for efficiency rather than a smaller vibrating plate or impact-type compactor that might be more appropriate in some settings. A contractor's or designer's preference for the larger equipment isn't a feasibility issue.

## Getting From Here to There—Outdoor Recreation Access Routes

Section 2.0 of the FSORAG defines an outdoor recreation access route (ORAR) as a continuous, unobstructed path intended for pedestrian use that connects constructed features within a picnic area, campground, developed trailhead, or other developed recreation area. Figure 27



Figure 27—There would be no point in providing a viewing area for the gorgeous Mendenhall Glacier in Alaska if people couldn't get there from the parking area. ORARs are all about getting around.

shows an ORAR connecting a parking lot and scenic overlook. ORARs must meet the required provisions for accessibility.

The definition of a developed recreation area is the same as the Forest Service's infrastructure (Infra) database definition: *A discrete place containing a concentration of facilities and services used to provide recreation opportunities to the public and evidencing a significant investment in facilities and management under the direction of an administrative unit in the National Forest System. A developed site or area is managed for use by forest visitors for a specific purpose or purposes, and contains constructed features that were installed for the visitor's convenience or for interpretation.*

ORARs are not required in areas within the National Forest System that are managed as general forest areas (GFAs). GFAs have minimal development and are available for recreation and other uses. GFAs don't include wilderness areas, developed recreation areas, or administrative sites.

While some constructed features such as picnic tables, fire rings, and toilet buildings may be provided in GFAs, these features are provided for resource protection rather than for visitor convenience. In GFAs, constructed features don't have to be connected by an ORAR.

In developed recreation areas, ORARs ensure that visitors can move independently from their camping or picnic spot to the other constructed features provided at the site or from the parking area to any constructed features. ORARs must meet requirements for running and cross slopes, resting intervals, surface, clear tread width, passing spaces, tread obstacles, protruding obstacles, openings, edge protection, and stairs.

### Slopes and Resting Intervals for ORARs

ORARs are to be designed with a running slope ratio of 1:20 (5 percent) or less (figure 28). Steeper terrain may make this difficult to achieve. Visitors can negotiate steeper slopes for short distances, so running slopes up to 1:12 (8.33 percent) are permitted for up to 50 feet (15 meters), and running slopes of up to 1:10 (10 percent) are permitted for up to 30 feet (9 meters). To ensure that the ORAR isn't designed as a series of steep segments, no more than 15 percent of the total length of the ORAR may exceed a slope of 1:12 (8.33 percent). Running slope is the lengthwise slope of an ORAR, parallel to the direction of travel.

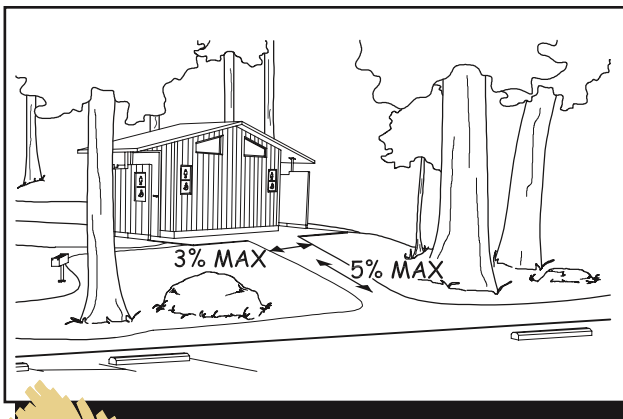

Figure 28—Determining the slope ratio.

Cross slopes—the side-to-side slope of an ORAR—can't exceed 1:33 (3 percent, see figure 28), although an exception permits a cross slope of up to 1:20 (5 percent) if necessary for proper drainage.



### CONSTRUCTION TIP—

#### **What is a slope ratio?**

Slopes are often described as a ratio of vertical distance to horizontal distance, or rise to run. For instance, a slope of 1:20 means that for every 1 foot of vertical rise, there are 20 feet of horizontal distance, or for every meter of vertical rise, there are 20 meters of horizontal distance (figure 29).

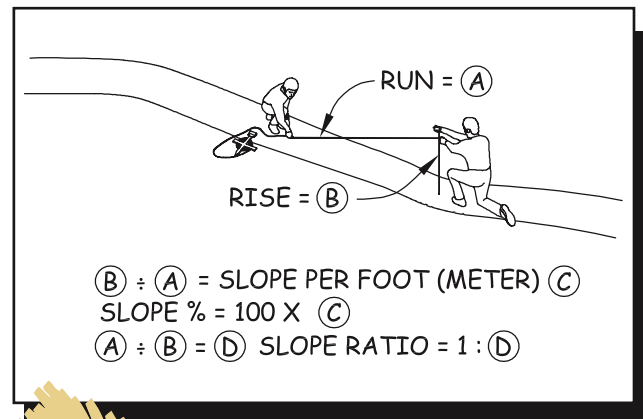

Figure 29—The basic slope requirements for ORARs and beach access routes.

Resting intervals are relatively level areas that provide an opportunity for people to catch their breath before continuing along the ORAR. These intervals are required any time the running slope exceeds 1:20 (5 percent). A resting interval must be at least 60 inches (1,525 millimeters) long and at least as wide as the ORAR leading into it.

The slopes of a resting interval can't exceed 1:33 (3 percent) in any direction (figure 30).

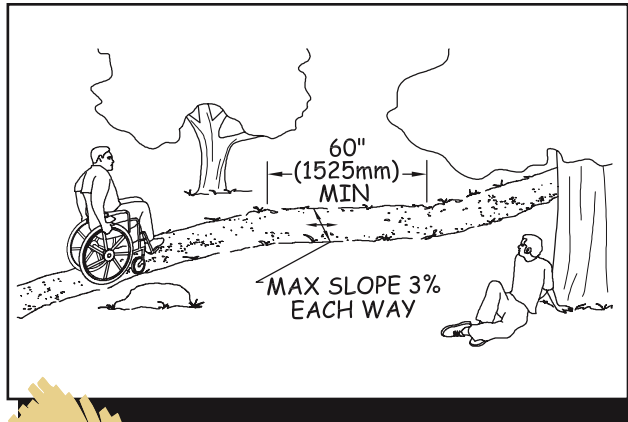

Figure 30—The basic resting interval requirements for ORARs.

Where running slopes are between 1:20 (5 percent) and 1:12 (8.33 percent), resting intervals must be provided at least every 50 feet (15 meters). For slopes from 1:12 (8.33 percent) to 1:10 (10 percent), resting intervals must be provided at least every 30 feet (9 meters). Depending on the design and location, the intersection of two ORARs may act as a resting interval.

Meeting the slope requirements for an ORAR may be more difficult when altering an existing site than it would be in new construction. Accessibility was seldom considered when older developed recreation areas were designed. Many campgrounds and picnic areas were located in spectacularly scenic settings, but on steep terrain. Complying with the slope provision in these areas may be difficult without a fundamental change to the recreation environment, so exceptions are provided for alteration projects where a condition for departure exists. This is one of only two instances where the FSORAG makes a distinction between new construction and alterations. The second exception is campground alterations, discussed later in this chapter.

**In alterations only** and where a condition for departure exists, exceptions are provided that permit running slopes up to 1:12 (8.33 percent) for 100 feet (30 meters), and up to 1:10 (10 percent) for 50 feet (15 meters). When these slopes are used, resting intervals are required every

100 feet (30 meters) and 50 feet (15 meters), respectively. Even with those exceptions, it may still not be possible to comply with the slope provision without drastically affecting the site. In these cases, a general exception to the entire slope provision is included if a condition for departure exists.

Where this occurs, the ORAR doesn't have to meet any of the slope requirements. However, designers should attempt to comply with the general slope requirement first, then each exception in order, to assure that the final design meets the highest possible technical provisions.

This exception **does not apply** to new construction. When planning for a new facility, the natural terrain and the general accessibility of the area itself should be part of the site selection criteria because compliance with ORAR provisions is required for new construction.

#### DESIGN TIP—

#### ***When should handrails be used on outdoor stairs?***

The use of outdoor stairs should be avoided wherever possible. Sometimes, an alteration project at an existing developed recreation site includes an area where stairs can't be avoided. The amount of use, safety, and the avoidance of the appearance of over development all are important considerations when deciding whether handrails are necessary and how many should be provided. For example, 5-foot wide stairs at a campsite may have just one handrail in the center to accommodate low-volume, two-way traffic. Treads that are just wide enough for one-way traffic could have one handrail. Two handrails may be needed if stairs are provided in high-traffic areas.

Handrails are not required for stairs in GFAs. Handrails may be provided if they are needed for safety.

### Surfaces for ORARs

The surface of an ORAR and the surface surrounding constructed features must be firm and stable. No exceptions are allowed. Slip resistance is not required because leaves and needles, dirt, ice, snow, and other surface debris and weather conditions are components of the natural environment that would be difficult, if not impossible, to avoid.

The FSORAG defines a firm surface as a surface that is not noticeably distorted or compressed by the passage of a device that simulates a person using a wheelchair. A stable surface is defined as a surface that is not per-

manently affected by normally occurring weather conditions and can sustain wear and tear during normal use between planned maintenance cycles. During the planning process, the compaction qualities of natural soils should be evaluated under weather conditions that occur normally when the surface will be used.

If the natural soils won't provide a firm and stable surface, soil stabilizer or artificial surfacing will be needed. The Forest Service Technology and Development report, *Soil Stabilizers on Universally Accessible Trails*, contains information about the effectiveness of soil stabilizers. It is available at: <http://www.fs.fed.us/eng/pubs/pdf/00>

34



#### DESIGN TIP— *Paving the wilderness?*

Does a firm and stable surface always mean concrete and asphalt? No! The surface provision states that the type of surface material used should be appropriate to the setting and level of development. Some natural soils can be compacted so they are firm and stable. Other soils can be treated with stabilizers without drastically changing their appearance. Many

surfaces that appear natural and that meet the firm and stable requirements also are available on the market. Designers are encouraged to investigate these options and use surfacing materials that are consistent with the site's level of development and that require as little maintenance as possible.

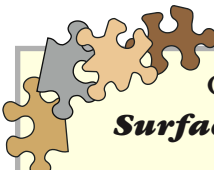

#### CONSTRUCTION TIP— *Surfacing materials*

Generally, the following materials provide firmer surfaces that are more stable:

- Crushed rock (rather than uncrushed gravel)
- Rock with broken faces (rather than rounded rocks)
- A rock mixture containing a full spectrum of sieve sizes (rather than a single size)
- Hard rock (rather than soft rock that breaks down easily)
- Rock that passes through a 1/2-inch (13-millimeter) screen (rather than larger rocks)
- Rock material that has been compacted into 3- to 4-inch (75- to 100-millimeter) thick layers (rather than thicker layers)
- Material that is moist, but not too wet, before it is compacted (rather than material that is compacted when it is dry)
- Material that is compacted with a vibrating plate compactor, roller, or by hand tamping (rather than material that is laid loose and compacted by use)



231202.pdf and <http://www.fbwa.dot.gov/environment/fspubs/00231202/>.

Firm and stable surfaces prevent assistive devices from sinking into the surface, which would make movement difficult for a person using crutches, a cane, a wheelchair, or other assistive device. In the accessibility guidelines, the standard assistive device is the wheelchair because its dimensions, multiple moving surface contact points, and four wheels often are difficult to accommodate. If a person using a wheelchair can use an area, most other people also can use that area.



#### DESIGN TIP—

#### ***What is firm and stable?***

In the late 1990s, the Access Board funded an Accessible Exterior Surfaces research project conducted by Beneficial Designs of Minden, NV. Results of the study are available on the Access Board's Web site at: <http://www.access-board.gov/research/Exterior%20Surfaces/exteriorsarticle.htm>. Figure 31 shows the rotational penetrometer tool that can be used to evaluate surfaces. For further information, consult Beneficial Designs' Web site at: <http://www.beneficialdesigns.com/>. One of the results of the project was development of a scientific method for determining firm and stable exterior surfaces.

What sort of surface is firm and stable? In general, if the answer to both of the following questions is *yes*, the surface is probably firm and stable.

- Could a person ride a narrow-tired bicycle across the surface easily without making ruts? (The bicycle tires are similar to large rear wheels of a wheelchair.)
- Could a folding stroller with small, narrow plastic wheels containing a 3-year-old be pushed easily

*Continued* ➤

stroller's wheels are similar to the front wheels of a wheelchair.)

While this method for determining firmness and stability isn't scientifically accurate, it has proven to be effective.



Figure 31—Using the rotational penetrometer to determine whether a surface is firm and stable.

#### ***Clear Tread Width and Passing Spaces for ORARs***

Clear tread width means the width of the traveled surface on the ground and also above the ground between obstacles (figure 32). The minimum clear tread width of an ORAR is 36 inches (915 millimeters), which is wide enough to allow unobstructed passage by a wheelchair. Where a condition for departure exists, such as when an ORAR must be routed between two large boulders that can't be removed, then the clear tread width may be reduced to not less than 32 inches (815 millimeters) for a maximum distance of 24 inches (610 millimeters).

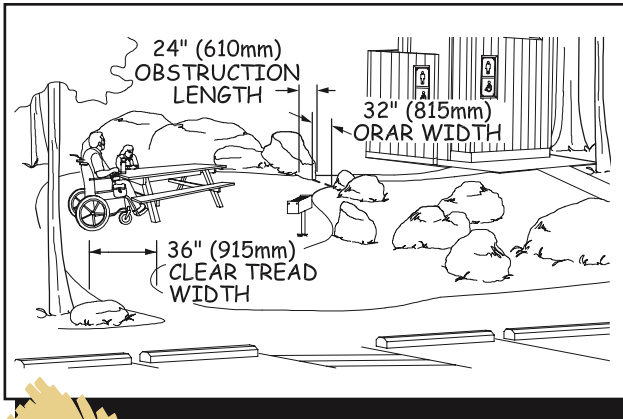

Figure 32—The clear tread width is the width of the unobstructed traveling surface.

**DESIGN TIP—**  
***How wide should the access route be?***

36

The 36-inch (915-millimeter) minimum clear tread width is just that—a minimum. To determine how wide the ORARs in a project should be, look at the level of development of the site and how it will be used. In a more highly developed area, a 48- or 60-inch- (1,220- or 1,525-millimeter-) wide ORAR may be appropriate, while a 36-inch- (915-millimeter-) wide tread may be a better fit in a less developed site.

All ORARs in a developed recreation area don't necessarily have to be the same width. It may make sense to vary the width, depending on the location of the ORAR. For example, a designer may decide to make the main ORAR 60 inches (1,525 millimeters) wide if it connects campsites to important constructed features, such as a rustic outdoor amphitheater, toilet buildings, or water hydrants.

Secondary ORARs, such as a spur from the main ORAR to a quiet, intimate path along a stream, may be only 36

inches (915 millimeters) wide. Consider how many people will likely be using the ORAR at the same time and how they will want to use it—single file or walking and talking side by side—and design accordingly.

Two wheelchairs need 60-inch- (1,525-millimeter-) clear tread width to pass comfortably and safely on an ORAR. However, this width isn't always appropriate or required. Where the clear tread width of an ORAR is less than 60 inches (1,525 millimeters), passing spaces are required at least every 200 feet (60 meters). If this isn't possible because of a condition for departure, an exception is provided that permits passing spaces to be 300 feet (90 meters) apart. Passing spaces must be at least 60 inches (1,525 millimeters) wide (including the ORAR width) by 60 inches (1,525 millimeters) long (figure 33).

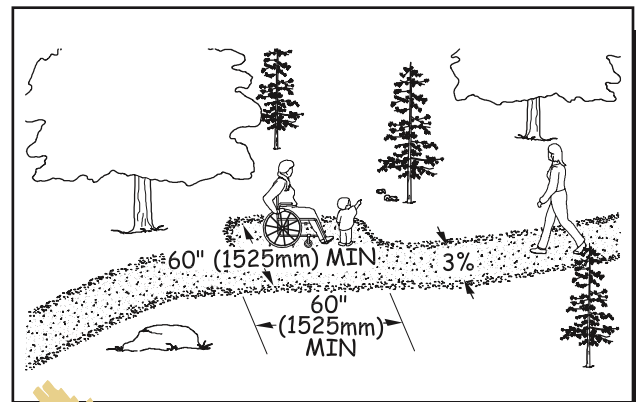

Figure 33—A passing space for an ORAR or a beach access route.

Another option allows a T-intersection of two ORARs or other walking surfaces to be a passing space (figure 34), provided that the arms and stem of the T-shaped space extend at least 48 inches (1,220 millimeters) beyond the intersection. Either configuration would provide enough room for someone to move to the side and let an oncoming person pass along the ORAR. The cross slope of a passing space shouldn't exceed 3 percent.

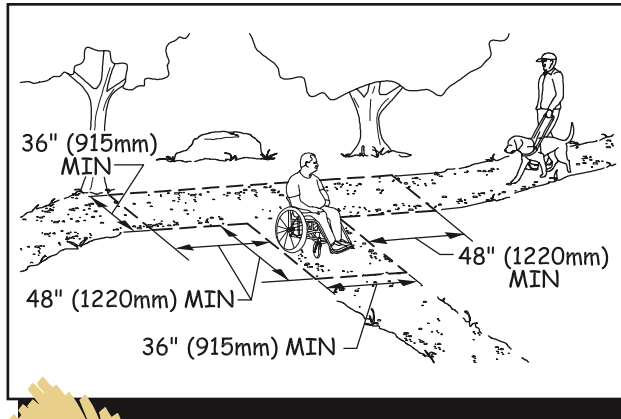

Figure 34—A “T” Intersection for passing on an ORAR or a beach access route.

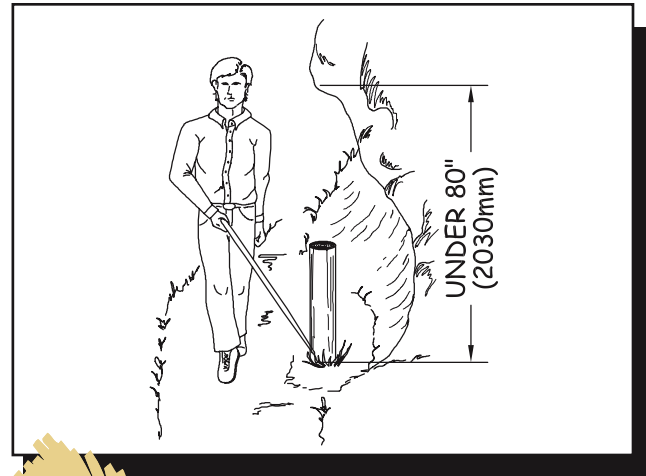

Figure 35—A warning barrier is required wherever vertical clearance is insufficient.

### Tread Obstacles on ORARs

A tread obstacle is anything that interrupts the evenness of the tread surface. On ORARs, an obstacle may occur where a tree root or rock protrudes above the surface or where two different surfaces abut, such as when a concrete path joins an asphalt path. If they are pronounced, tread obstacles can pose a serious tripping hazard. Where tread obstacles exist along an ORAR, they can't be more than 1 inch (25 millimeters) high. If compliance with this provision isn't possible because of a condition for departure, an exception permits obstacles up to 2 inches (50 millimeters) high, provided that the obstacle is beveled with a maximum 1:2 slope.

### Protruding Objects and ORARs

Protruding objects extend into the clear width area of an ORAR from beside or above the ORAR. Leaning tree trunks, rock ledges, and branches are common protruding objects. The ORAR must provide at least 80 inches (2,030 millimeters) of clear headroom (figure 35), which is the same requirement as ABAAS section 307. Where the vertical clearance of an ORAR is reduced to less than 80 inches (2,030 millimeters) because of a condition for departure, a barrier to warn blind and visually impaired persons must be provided. This exception allows an ORAR to pass under ledges or other naturally constricted areas.

### Openings in ORAR Surfaces

Openings are gaps in the surface of an ORAR. Gaps include spaces between the planks on a boardwalk or in a drainage grate. Openings that are big enough for wheels, cane or crutch tips, or shoe heels to drop through are hazards that shouldn't exist in pedestrian routes (figure 36). Openings up to  $\frac{1}{2}$  inch (13 millimeters) wide are permitted. Elongated openings must be placed so that the long dimension runs perpendicular



Figure 36—Big openings in ORAR surfaces are a bad idea.

or diagonal to the primary direction of travel (figure 37). Openings narrower than  $\frac{1}{4}$  inch (6.4 millimeters) are allowed parallel to the dominant direction of travel.

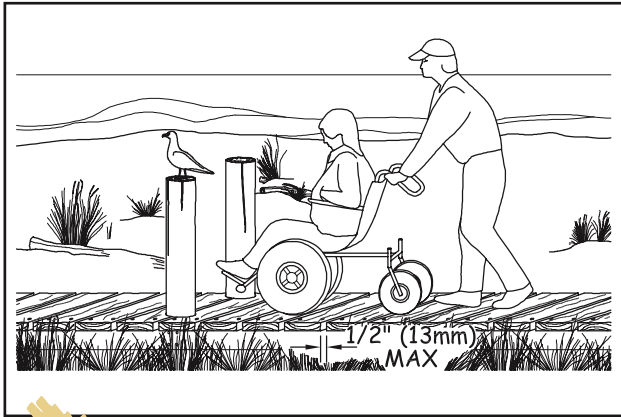

Figure 37—Elongated openings must be perpendicular to the direction of travel.

38

### Edge Protection for ORARs

Edge protection is a raised curb, wall, railing, or other structure that defines the edge of a travel surface and helps keep people and assistive devices from accidentally falling off the edge. Edge protection is not required for accessibility on ORARs. However, where designers and managers have determined that edge protection is required for safety or other reasons, the FSORAG requires curbs to be at least 3 inches (76 millimeters) high (figure

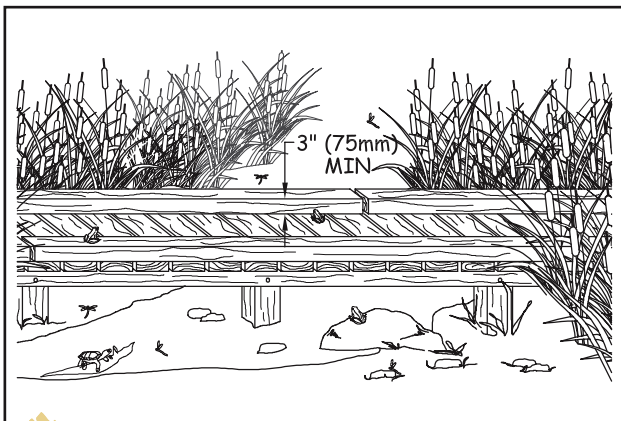

Figure 38—Edge protection is optional on an ORAR, but if present, edge protection must be at least 3 inches high.

38). This is higher than required by the ABAAS because objects less than 3 inches (75 millimeters) high aren't easy to see or detect outdoors and could become a tripping hazard.

## Getting to the Water—Beach Access Routes

A beach access route is a continuous unobstructed path intended for pedestrian use that crosses the surface of the beach. Because beach access routes and ORARs perform similar functions, their provisions are closely related. Section 3 of the FSORAG covers beach access routes.

Beaches are grouped into three general types:

- Coastal beaches
- River beaches
- Lake, pond, or reservoir beaches

Beach access routes allow pedestrians to get to the water so they can play, swim, or participate in other shoreline activities. Areas where entry into the water may be possible, but no specific path or route is provided, aren't beach access routes.

A beach access route is a pathway over the surface of the beach itself that leads to the water. The route leading to the edge of the beach surface in a developed recreation area is an ORAR.

The FSORAG has different requirements for new and existing beaches. A new beach is a site where a beach is created artificially by importing sand or other beach material. At least one beach access route must be provided for each linear half mile (800 meters) of new beach. The beach access route must be permanent and extend to the high tide level for coastal beaches, the mean high water level for river beaches, or the normal recreation



water level for lakes, ponds, and reservoirs (figures 39, 40, and 41).

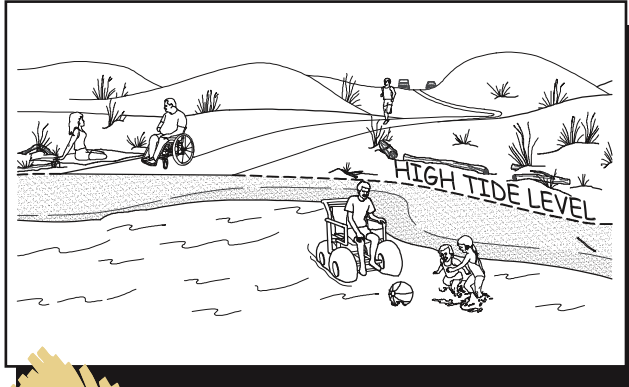

Figure 39—The high tide level on a coastal beach.

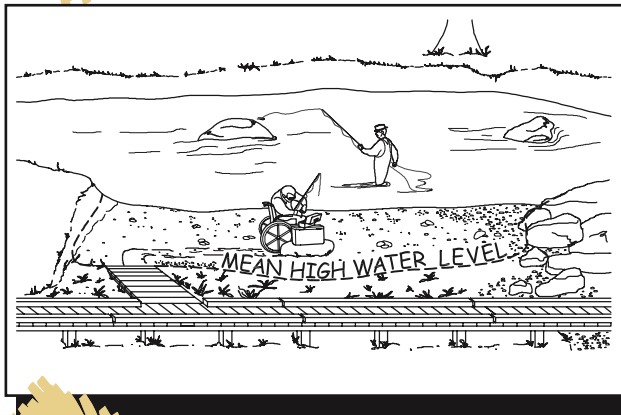

Figure 40—The mean high water level on a river.

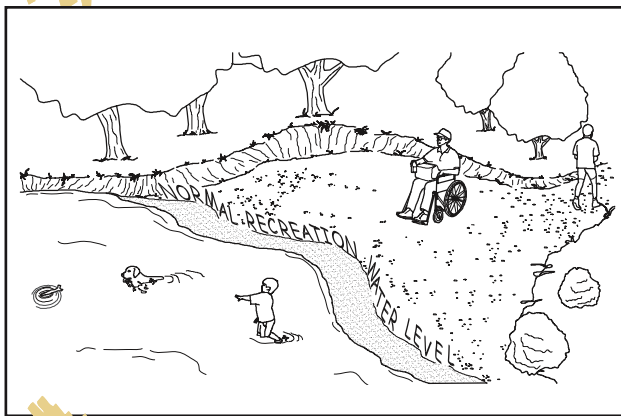

Figure 41—The normal recreation water level on a lake.



**DESIGN TIP—**

***How far down the beach must the access route go?***

Beach access to the water will vary considerably depending on geographic locations because the difference between low and high tides varies from place to place. For example, a beach in Alaska may experience tidal differences of up to 30 feet (9 meters); beaches in Florida will have much smaller differences between the tides. The high tide mark is a reasonable location to stop constructed features; they are much more likely to wash out below this point. The mean high water level applies to rivers and the normal recreation water level applies to lakes.

In some locations, it may make sense to continue the beach access route below the mean high water level or normal recreation water level. In locations with significant variations in water level through the recreation season, visitors appreciate extended access routes where they can be constructed (figure 42).

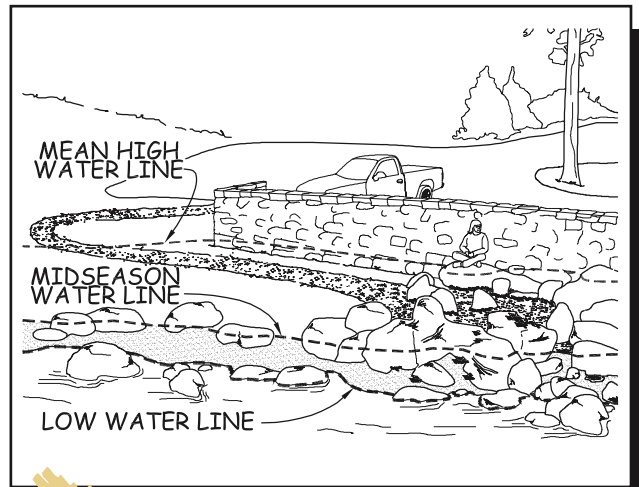

Figure 42—This beach access route is partly inundated every year.

Beach access routes must be provided to existing beaches when a pedestrian route is constructed from a developed site to or along the edge of an existing beach, or when an existing beach access route is altered. It must extend to the high tide level, mean high water level, or normal recreation water level as described for new beaches, so that visitors can participate in water-related recreation activities (figure 43).



Figure 43—Everybody ought to be able to get to the beach.

Several exceptions are permitted for routes on existing beaches. Designers and managers can choose to use a temporary beach access route on existing beaches for administrative, environmental, or operational reasons. Factors that might influence a decision in favor of a temporary beach access route include the restrictive permits that may be required in coastal and shoreline areas, or excessive wave action that can cause erosion, quickly turning a permanent beach access route into a hazard. Vehicular access or access provided by an assistive device isn't an acceptable temporary beach access route.

Routes created solely for shoreline maintenance don't have to meet beach access route requirements; neither

do undeveloped public easements, nor access trails when another beach access route meets the requirements and accesses the same beach within  $\frac{1}{2}$  mile (800 meters).

Beach access route requirements are not triggered when an existing beach is being replenished with new material to restore eroded areas, so long as no other improvements are made. Beach access routes are not required when the pedestrian route, boardwalk, or pathway along the edge of an existing beach is elevated 18 inches (455 millimeters) or higher above the beach surface.

### **Slopes and Resting Intervals for Beach Access Routes**

Running slopes—the slope parallel to the direction of travel—on a beach access route may be up to 1:20 (5 percent) for any distance, up to 1:12 (8.33 percent) for 50 feet (15 meters), and up to 1:10 (10 percent) for 30 feet (9 meters). To ensure that the beach access route is not designed as a series of steep segments, no more than 15 percent of the total length may exceed a slope of 1:12 (8.33 percent). As with ORARs, **for alteration projects only**, the requirement for running slope doesn't have to be met if there is a condition for departure. Cross slopes—the side-to-side slope—may not exceed 1:33 (3 percent). The basic slope requirements are the same as for ORARs (see figure 29).

Resting intervals identical to those required for an ORAR are required whenever the running slope of a beach access route exceeds 1:20 (5 percent). See *ORAR Slopes and Resting Intervals* for resting area requirements.

### **Maneuvering Space for Beach Access Routes**

Space must be provided at the high tide level, mean high water level, normal recreation water level, or at the end of a beach access route so someone using an assistive device can move around safely. This maneuvering space is different from a passing area, because maneuvering space

can't overlap the beach access route. Other requirements, such as running slope and cross slope, are the same as described for an ORAR passing space.

### **Surface and Clear Tread Width on Beach Access Routes**

A beach access route must have a firm and stable surface and have 36-inch (915-millimeter) minimum clear tread width. If a condition for departure exists, such as when a beach access route passes between a large boulder and a stream, the clear tread width may be reduced to not less than 32 inches (815 millimeters) for no longer than 24 inches (610 millimeters).

### **Passing Spaces on Beach Access Routes**

Where the clear tread width of a beach access route is less than 60 inches (1,525 millimeters), passing spaces are required at least every 200 feet (60 meters). No exception is permitted. Passing spaces are at least 60 inches (1,525 millimeters) wide by 60 inches (1,525 millimeters) long (see figure 33). Another option allows a T-intersection of two beach access routes or other walking surfaces to be a passing space, provided that the arms and stem of the T-shaped space extend at least 48 inches (1,220 millimeters) beyond the intersection (see figure 34). Either configuration would provide enough room for someone to move to the side and let an oncoming person pass. The cross slope of a passing space shouldn't exceed 3 percent.

### **Changes in Level on Beach Access Routes**

Obstacles along a beach access route must not be more than 1 inch (25 millimeters) high. There is no exception.

### **Protruding Objects on Beach Access Routes**

Protruding objects are things such as leaning trees, rock ledges, and driftwood that extend into the clear width

of a beach access route. At least 80 inches (2,030 millimeters) of clear headroom must be provided on beach access routes, the same requirement as ABAAS section 307. Where the vertical clearance of a beach access route is less than 80 inches (2,030 millimeters) because of a condition for departure, a barrier must be provided to warn people who are blind or visually impaired (see figure 35).

### **Openings in Beach Access Routes**

Openings are gaps in the surface of a beach access route. Gaps include spaces between the planks on a boardwalk and drainage holes in temporary or permanent surfaces. Openings that are big enough for wheels, cane or crutch tips, or shoe heels to drop through or get stuck in are hazards that shouldn't exist in pedestrian routes. Openings up to ½ inch (13 millimeters) wide are permitted. Elongated openings must be placed so that the long dimension runs perpendicular or diagonal to the primary direction of travel (see figure 37). An exception allows openings that are less than 1/4 inch (6.4 millimeters) wide to be placed parallel to the dominant direction of travel.

### **Edge Protection for Beach Access Routes**

Edge protection is required along beach access routes where the dropoff from the route to the beach is 6 inches (150 millimeters) or higher. Edge protection may be a curb, wall, railing, or other projecting surface that defines the edge of a pedestrian route and helps to keep people from falling off. Edge protection must be at least 2 inches (50 millimeters) high (figure 44). If the dropoff from the route to the beach is more than 1 inch (25 millimeters) but less than 6 inches (150 millimeters), edge protection isn't required, but the vertical edge of the dropoff must be beveled with a slope of 1:2.

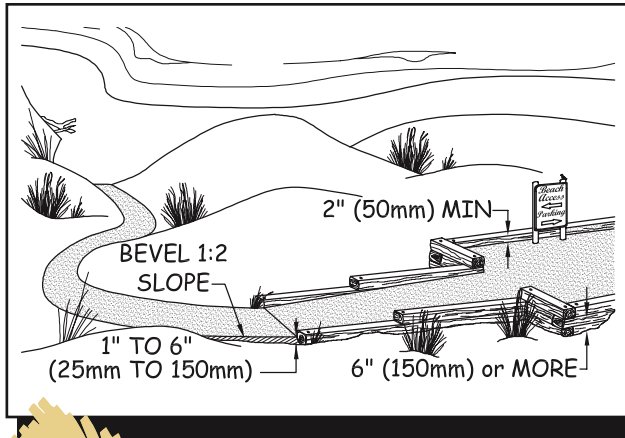

Figure 44—The requirements for edge protection on a beach access route.

## Providing Creature Comforts and Conveniences—Constructed Features

Constructed features are the site furnishings and other elements provided in picnic areas, campgrounds, and other developed recreation areas. The constructed features addressed in sections 4, 5, and 6 of the FSORAG include **picnic tables, cooking surfaces, camping units, parking spurs, tent pads and platforms, fire rings, wood stoves, fireplaces, utilities, utility sinks, benches, trash containers, and recycling containers.** Also included are **viewing areas, telescopes, periscopes, storage facilities for assistive devices, pit toilets, warming huts, outdoor rinsing showers, and signs.**

The Forest Service policy of universal design directs the agency to construct, purchase, and install only elements and constructed features that are accessible. For example, even if steep terrain or other conditions in an alteration project at a developed recreation area preclude complying with the slope provisions for the ORAR to a picnic table or camping unit, all the components and furnishings still must comply with the relevant sections of the FSORAG. Individuals can select the location where they

want to picnic or camp without being limited by the location of accessible features of the picnic or camping unit. This requirement includes all picnic tables, pedestal grills, and other features in a picnic area or campground if they are purchased or constructed by or on behalf of the Forest Service. The few exceptions to this general rule are explained below.

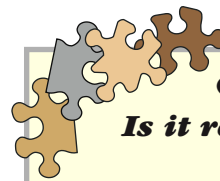

### CONSTRUCTION TIP—

#### *Is it really accessible?*

Manufacturers don't necessarily understand accessibility requirements. Some manufacturers advertise their products as "accessible" or "ADA compliant," even though they aren't. The only way to make sure that a product such as a picnic table or fire ring is truly accessible is to compare the dimensions of the product to the ABAAS or FSORAG requirements. Ask the manufacturer for the shop drawings or for the location of a retailer or campground near you where you can examine the product.

The FSORAG doesn't require that any particular constructed feature be provided in a picnic area or campground. If there were no plans to provide outdoor rinsing showers, utility sinks, or utility hookups at a campground, the FSORAG wouldn't require them to be installed. However, if a feature is provided, the FSORAG requirements must be met. The same principle applies in general forest areas (GFAs). The FSORAG doesn't require constructed features and site furnishings to be provided in GFAs, but if they are provided, they must meet the requirements of the FSORAG.

Constructed features are addressed in three sections in the FSORAG: picnic areas, campgrounds, and other. The divisions aren't absolute, as some features addressed in one section may also be found in another. For example, picnic tables are addressed under *Constructed Features*



for Picnic Areas, but the same technical provisions apply to tables provided in campgrounds. Trash receptacles are covered under *Other Constructed Features*, even though trash receptacles are commonly found in picnic areas and campgrounds.

Clear floor or ground space is required at each constructed feature, but the size of the clear area varies with the feature. The differences are based on how each feature is used and whether users need to approach just one side of the feature or all sides of it. For instance, users may only need to get to the front of a water hydrant, but they need to get to all sides of a picnic table or fire ring. When several constructed features are grouped together, their clear spaces may overlap. For example, the 48-inch (1,220-millimeter) clear space around a picnic table may overlap the 48-inch (1,220-millimeter) clear space around a pedestal grill provided in a picnic unit. The clear space of a constructed feature is **not** allowed to overlap the ORAR connecting the feature to the rest of the developed area.

### **Reach Ranges and Operability Requirements**

In this guide, you will see the requirement “Controls and operating mechanisms must comply with the provisions for reach ranges and operability specified in ABAAS sections 308 and 309” whenever a constructed feature has buttons, knobs, handles, or other controls or operating devices. One of the basic principles of universal design and accessibility is to provide controls that almost everyone can reach and use.

The ABAAS section 309 requires that controls and operating mechanisms have to be operable with one hand without tight grasping, pinching, or wrist twisting, using a force no greater than 5 pounds (2.2 newtons).

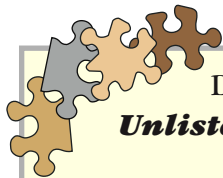

#### DESIGN TIP—

#### ***Unlisted features***

What if a designer wants to provide a constructed feature that isn't addressed in the FSORAG? Lantern hooks often are provided in developed campgrounds, but the FSORAG does not address lantern hooks. In this case, designers would need to go back to the basic building blocks of accessible design—wheelchair dimensions, clear space, and reach ranges found in the ABAAS.

Using that information and the principles of universal design, designers would know that if the hooks were to be usable to the greatest number of campers

of all ages, with and without disabilities, the hooks would need to be placed within the reach range of someone in a seated, as well as a standing, position.

This could be accomplished by a mechanical device to raise the hook or by installing two hooks at the proper levels. The lantern hook also would need to have the appropriate clear space around it to allow someone in a wheelchair to approach it from the front or the side. The clear space for the lantern hook shouldn't overlap the ORAR.

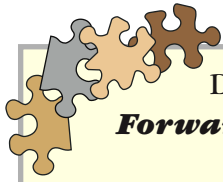

DESIGN TIP—

**Forward reach and side reach**

When the terms forward reach and side reach are used in the context of accessibility, they don't refer to the object a person is trying to reach. They refer to the position of the person doing the reaching. A forward reach means that the person is facing the object and reaching forward toward it (figure 45). A side reach means that the person's side is closest

to the object, and the person is reaching either to their right or left towards the object (figure 46). People using wheelchairs can't reach as far forward over their laps as they can reach to the side. They also need different sized spaces to position their wheelchairs to be able to reach objects from the front and from the side. This is why there are different height and clear floor space requirements for forward and side reaches.

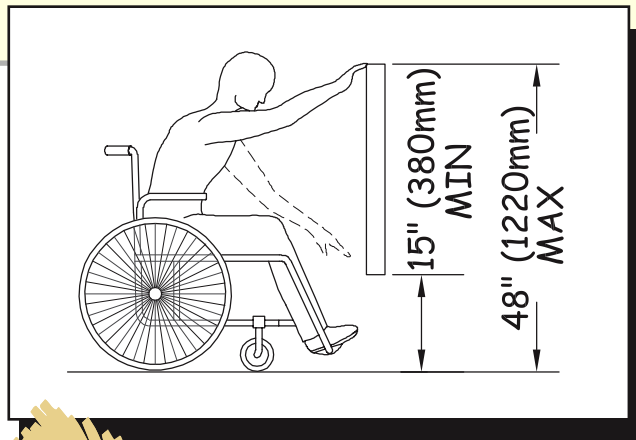

Figure 45—The requirements for unobstructed forward reach.

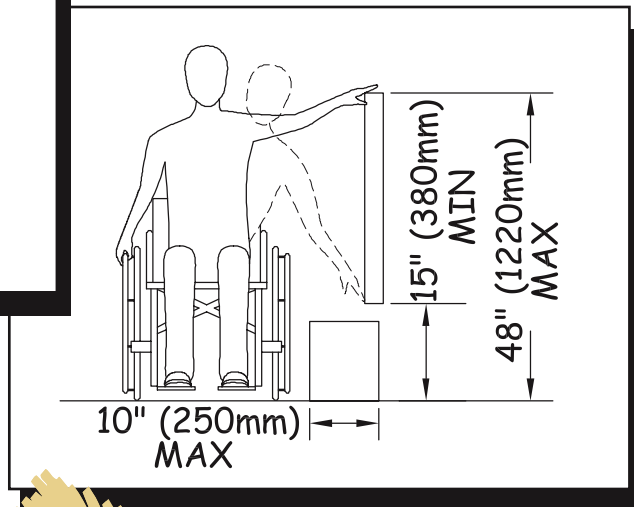

Figure 46—The requirements for unobstructed side reach.

Section 308 of the ABAAS identifies the following reach requirements:

**Unobstructed Reaches**—Where a forward or side reach is unobstructed, the object to be reached must be no higher than 48 inches (1,220 millimeters) and no lower than 15 inches (380 millimeters) above the floor or ground (see figures 45 and 46). For side reaches only, an object that isn't more than 10 inches (255 millimeters) wide and is below the object to be reached doesn't count as an obstruction.

**Obstructed Forward Reach**—Where an object must be reached over an obstruction, the clear floor space must extend beneath the obstruction for at least as far as the reach depth over the obstruction. The object to be reached can't be under the obstruction. If the obstruction is 20 inches (510 millimeters) deep or less, the object to be reached must be between the top of the obstruction and 48 inches (1,220 millimeters) above the floor or ground (figure 47). If the obstruction is more than 20 inches (510 millimeters) deep, the object to be reached must be between the top of the obstruction and 44 inches (1,120 millimeters) above the ground or floor (figure 48). The obstruction can't be more than 25 inches (635 millimeters) deep.

**Obstructed Side Reach**—For side reaches, obstructions can't be more than 34 inches (865 millimeters) high or 24 inches (610 millimeters) deep. The object to be reached can't be under the obstruction. If the reach depth is 10 inches (255 millimeters) or less, the object to be reached must be 48 inches (1,220 millimeters) or less above the ground or floor (figure 49). If the reach depth is between 10 and 24 inches (255 and 610 millimeters), the object to be reached can't be more than 46 inches (1,170 millimeters) above the floor or ground (figure 50).

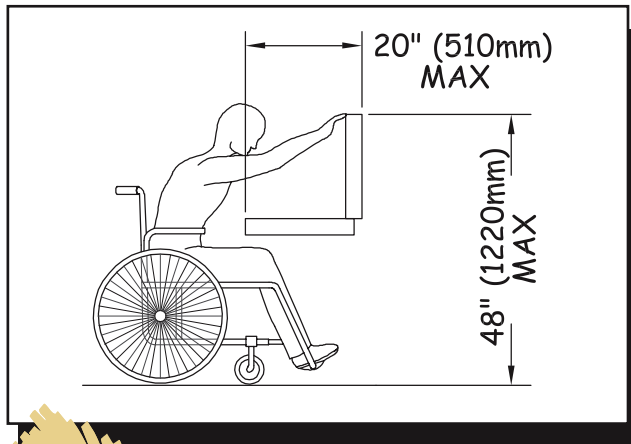

Figure 47—The requirements for obstructed high forward reach, narrower obstacles

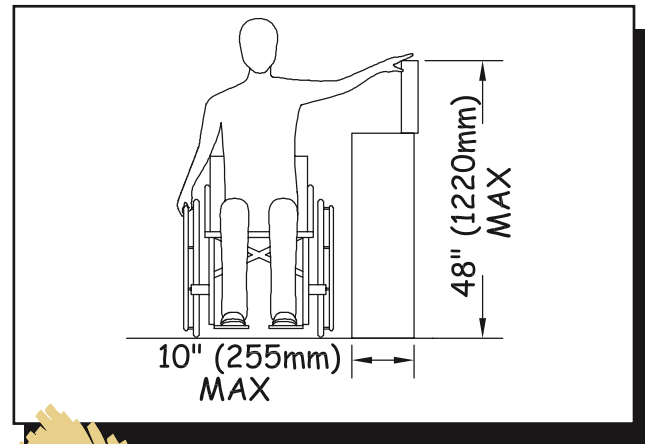

Figure 49—The requirements for obstructed high side reach, narrower obstacles.

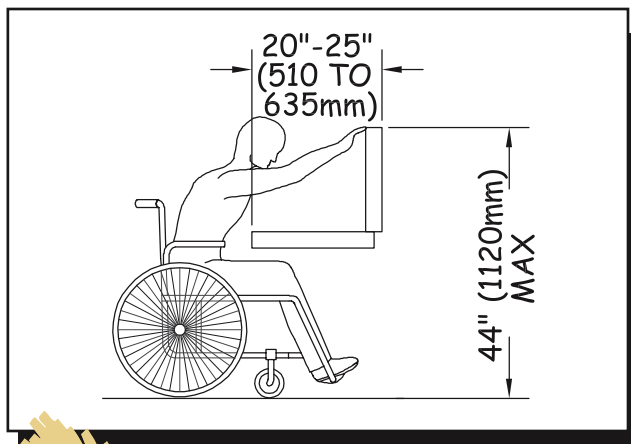

Figure 48—The requirements for obstructed high forward reach, wider obstacles.

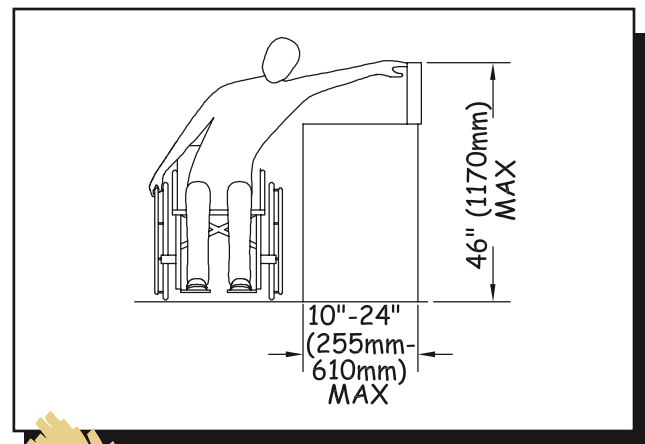

Figure 50—The requirements for obstructed high side reach, wider obstacles.

### Grab Bars

Grab bars are usually provided in buildings to provide stability and allow a person to use his or her arms to assist in movement over short distances. The most common location for grab bars is in restrooms. However, grab bars are also necessary at outdoor rinsing showers and at pit toilets that have walls around them. Grab bars must comply with the reach range requirements of ABAAS section 308, as explained in *Reach Ranges and Operability Requirements*. They must also comply with the size, strength, finish, and position requirements in ABAAS section 609, as explained below.

Grab bars with circular cross sections must have a diameter no less than 1¼ inches (32 millimeters) and no more than 2 inches (51 millimeters). Grab bars with noncircular cross sections can't be more than 2 inches (51 millimeters) across and must be 4 to 4.8 inches (100 to 120 millimeters) around. Figure 51 shows how this is measured.

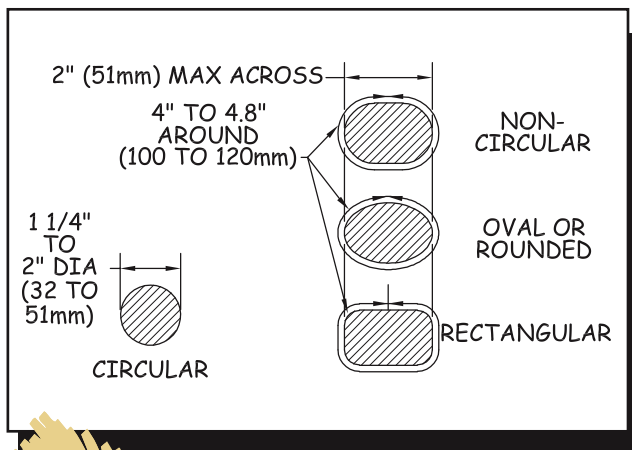

Figure 51—The requirements for the diameter and circumference of grab bars.

The space between the wall and the grab bar must be 1½ inches (38 millimeters). There must also be a space of 1½ inches (38 millimeters) between the grab bar and any projecting objects below or at the ends of the grab bar. There must be at least 12 inches (305 millimeters)

between the grab bar and any projecting objects above it, except for shower controls, shower fittings, and other grab bars, which only have to be 1½ inches (38 millimeters) from the grab bar.

Grab bars and any wall or other surfaces adjacent to grab bars must have rounded edges and can't have sharp or abrasive surfaces. Grab bars must be installed so they don't rotate within their fittings. They have to be strong enough to support 250 pounds (1,112 newtons) of pressure at any point on the grab bar, fastener, mounting device, and supporting structure.

More specific location requirements are explained in the sections for *Pit Toilets in General Forest Areas* and *Outdoor Rinsing Showers*.

### Constructed Features for Picnic Areas

Three constructed features are addressed in section 4 of the FSORAG—picnic units, picnic tables, and cooking surfaces.

**Picnic Units**—A picnic unit is a part of a picnic area that contains one or more constructed features used for picnicking by an individual or group separate from other parties using the recreation site. All constructed features provided in a picnic unit must meet the requirements explained below. The size of a picnic unit is determined by the type and number of constructed features provided and the required clear space around each feature.

Where two or more picnic units are provided in a developed recreation area, at least 20 percent, but never less than two of the units, must be connected by an ORAR to the other major features of the site. In a picnic area with 20 units, for example, all tables, grills, and other features must be accessible, and a minimum of four picnic units must be connected to the other major features at the site by an ORAR.



The 20 percent requirement is a minimum. In the spirit and intent of universal design, designers are encouraged to connect as many units by an ORAR as is feasible, given the specific natural constraints of the site, the level of development, and other considerations.

The FSORAG recognizes that the natural terrain often presents a real obstacle in the outdoor recreation environment. While terrain doesn't affect the accessibility of the constructed features provided in the unit, it could make it difficult to provide an ORAR for the picnic unit. It may not be possible to provide an ORAR for all picnic units without affecting the fundamental nature of the picnic area and the recreation opportunity.

**Picnic Tables**—All picnic tables must comply with requirements for accessible seating spaces, table clearance, slope, and surface. At least 20 percent of them must be connected by an ORAR to the other major constructed features at the recreation area. This is the same as, not in addition to, the ORAR connection requirement for picnic units. It is included here to ensure that everyone understands that even if no constructed features are provided other than picnic tables, an ORAR connection is still required. The 20 percent requirement is only a minimum; designers are encouraged to connect more picnic tables where that is feasible. Picnic tables in GFAs don't have to be connected to an ORAR.

Wheelchair seating spaces must be provided based on the length of a picnic table (figure 52). For tables up to 9 feet (2.7 meters) long, one space is required. Tables between 10 feet (3 meters) and 18 feet (5.5 meters) long require two wheelchair spaces, and so on for longer tables.

Knee space for wheelchair seating must be at least 30 inches (760 millimeters) wide, 19 inches (485 millimeters) deep, and 27 inches (685 millimeters) high, as

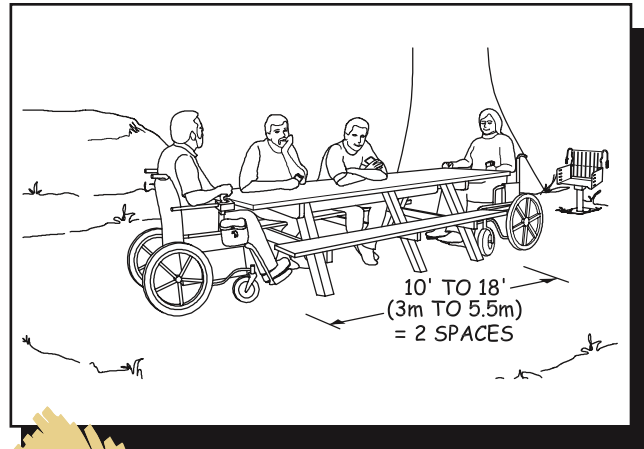

Figure 52— At least two spaces must be accessible at a 10- to 18-foot- (250- to 460- millimeter-) long picnic table.

measured from the ground or floor to the bottom of the tabletop. Toe clearance of at least 9 inches (230 millimeters) above the ground or floor must extend at least an additional 5 inches (25 millimeters) beyond the knee clearance. Figure 53 illustrates the required knee and toe space. Toe clearance is required to ensure that someone in a wheelchair is able to sit close to the tabletop, regardless of the design of the picnic table. If the table is constructed with one solid leg on each end, as opposed to an A-shaped frame or two individual legs on each end of the table that would allow the wheelchair to fit in

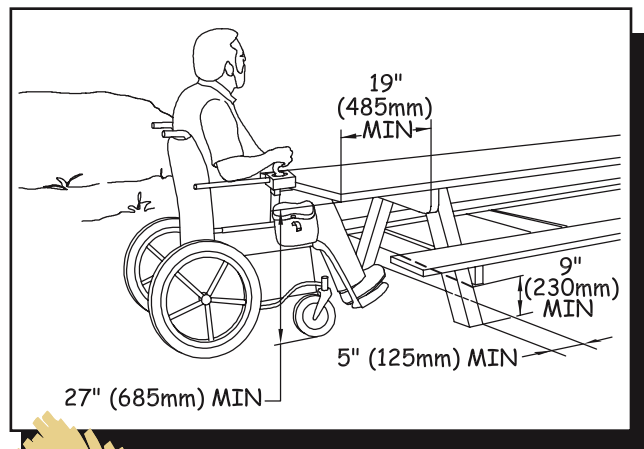

Figure 53—The requirements for knee and toe space at a picnic table.

between, the toes of a person in a wheelchair would hit the table leg at the end of the 19-inch (485-millimeter) knee space. Without the additional 5-inch (25-millimeter) toe clearance, a person in a wheelchair wouldn't be able to get close enough to the tabletop to use it comfortably.

Clear floor or ground space that is 30 inches by 48 inches (760 millimeters by 1,220 millimeters) must be provided at each wheelchair seating space and must be positioned to accommodate a forward approach to the table (figure 57). No exceptions to the wheelchair seating space requirements are permitted.

### CONSTRUCTION TIP— **Accessible picnic tables**

Picnic tables are tricky. Manufacturers often claim their tables are accessible even though they don't meet accessibility requirements. The only sure way to know whether a table is accessible is to check the dimensions.

Figures 54, 55, and 56 show some examples of accessible tables that can be built by contractors or Forest Service crews. Use the links to view or save AutoCAD drawings of the tables.

### DESIGN TIP— **Forward approach and side approach**

A forward approach means that the person is facing the object (figure 57). A side approach means that the person is beside the object (see figure 46). People need different-sized spaces to position their wheelchairs if they are in front of an object than if they are beside an object. This is why there are different clear floor or ground space requirements for forward and side approaches.

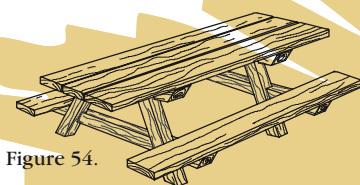

Figure 54.

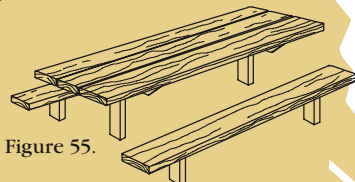

Figure 55.

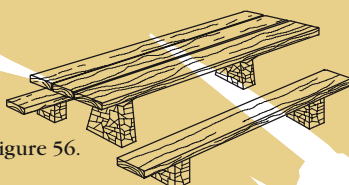

Figure 56.

Figure 54, 55, and 56—Three examples of accessible picnic tables. Plans are on the Forest Service's internal computer network at: <http://fsweb.wo.fs.fed.us/eng/facilities/accrec/>.

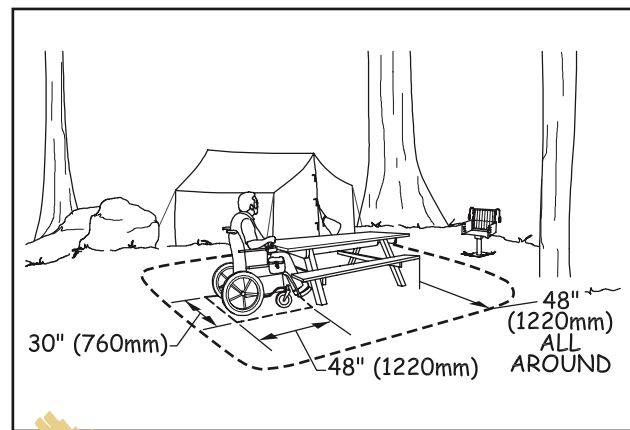

Figure 57—The requirements for clear space at a picnic table.

In addition to the clear floor or ground space for each wheelchair seating space, a 48-inch (1,220-millimeter) clear floor or ground space is required around the usable portions of the table (figure 57). Table clearance is measured from the table seat out. Where a condition for departure exists, the table clearance may be reduced

to 36 inches (915 millimeters). No other exceptions are permitted. The clear space must be adjacent to the ORAR, but it may not overlap the ORAR.

The slope of the required clear floor or ground space for wheelchair seating spaces and for table clearance can't exceed 1:50 (2 percent) in any direction. An exception is provided that permits a maximum slope of 1:33 (3 percent) where surface conditions require a steeper slope for proper drainage. The surface of the clear floor or ground space must be firm and stable. The type of surfacing used should be appropriate to the setting and level of development. There are exemptions from the slope and surface requirements if a condition for departure exists. This is a particularly important exception for GFAs.

#### *Cooking Surfaces, Grills, and Pedestal Grills—*

Requirements for accessible cooking surfaces, grills, and pedestal grills include cooking surface height, controls, clear floor or ground space, slope, and surface. Figure 58 shows a typical pedestal grill. Each cooking surface, grill, and pedestal grill must comply with these provisions and at least 20 percent of them must be connected to the other major constructed features at the recreation area by an ORAR. This is the same as, not in addition to, the ORAR connection requirement for picnic units. Even if

no constructed features other than cooking surfaces are provided, an ORAR connection is still required. The 20 percent requirement is only a minimum; designers are encouraged to connect more cooking surfaces where it is feasible. Connection to an ORAR isn't required for cooking surfaces, grills, and pedestal grills located in GFAs.

The height of the cooking surface must be 15 inches (380 millimeters) to 34 inches (865 millimeters) above the ground or floor surface. This is based on the height for countertops and the minimum low forward reach range in ABAAS. An exception clarifies that this height range doesn't apply to the grill attached to a fire ring because the grill needs to be close to the fire for food to cook properly. More information about fire ring requirements is available in *Fire Rings, Fireplaces, and Wood Stoves*.



#### CONSTRUCTION TIP—

#### ***Installing a pedestal grill***

Most pedestal grills have adjustable cooking heights. If grills are installed so that the highest setting is 34 inches (865 millimeters) above the ground, users can lower the grill to a convenient height.

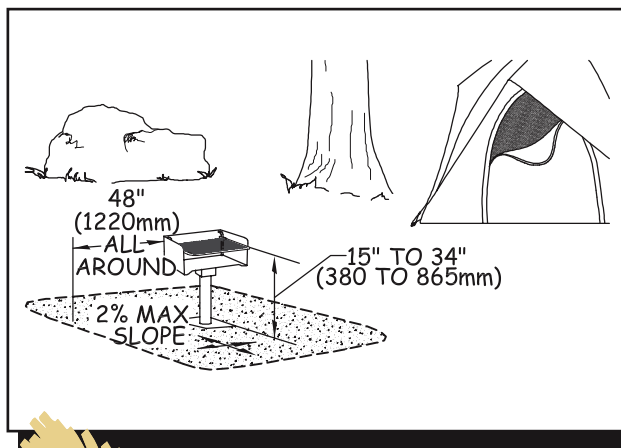

Figure 58—The requirements for height, clear space, and reach range for a pedestal grill.

Controls and operating mechanisms for cooking surfaces, grills, and pedestal grills must comply with the provisions for reach ranges and operability specified in ABAAS sections 308 and 309 and explained in *Reach Ranges and Operability Requirements*.

A clear floor or ground space that is at least 48 inches (1,220 millimeters) deep and 48 inches (1,220 millimeters) wide, as measured from the cooking surface, must be provided around all usable portions of the cooking surface (figure 58). If a pedestal grill can rotate 360 degrees and all positions along that rotation are usable,

the 48-inch (1,220-millimeter) clear space must completely surround the grill. An exception permits the clear floor or ground space to be reduced to 36 inches (915 millimeters) if a condition for departure exists. The clear space must be adjacent to the ORAR, but it can't overlap the ORAR. This clear space is required for safety. Restricted maneuvering room could increase the risk of getting burned.

The slope of the clear floor or ground space can't exceed 1:50 (2 percent) in any direction. Where needed for proper drainage, an exception permits the slope to be up to 1:33 (3 percent) in any direction. The surface of the clear floor or ground space must be firm and stable, and the surface material used should be appropriate to the setting and level of development. As with the picnic table, there are exceptions from the slope and surface requirements if a condition for departure exists. This is particularly relevant where cooking surfaces, grills, and pedestal grills are installed in GFAs.

### Constructed Features for Developed Campgrounds

The FSORAG section 5 covers constructed features in developed campgrounds, including camping units, tent pads and platforms, fire rings, wood stoves, fireplaces, utilities, and utility sinks.

**Camping Units**—A camping unit is a part of a developed campground that is used by an individual or group for camping separate from other parties using the recreation site. A camping unit commonly includes the camp living area, a parking spur, and a space to pitch a tent (figure 59). The camp living area is the space where tables, fire rings, and grills are located, and is often adjacent to the parking spur. The FSORAG doesn't require a specific number or type of camp units or constructed features, but all camp units and constructed features must meet FSORAG requirements.

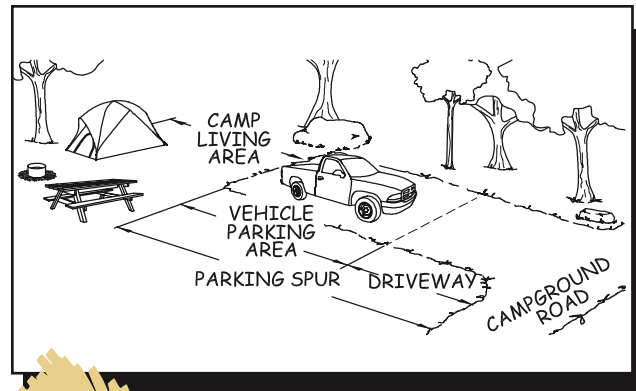

Figure 59—The parts of a camping unit.

**Camp Living Areas**—The surface of camp living areas must be firm and stable, and the surface material used should be appropriate to the setting and level of development.

Where walk-in camping is provided in a developed campground, an ORAR must connect the camp living area to the parking spur or parking lot. Depending on the terrain and whether the work is new construction or alteration, this may mean that it won't be possible to comply with the slope requirements for the ORAR to all walk-in units.

**Campground Parking Spurs**—The parking spur is divided into two parts. The driveway is the section of the parking spur that provides vehicular access and a transition between the campground road and a vehicle parking area. The vehicle parking area is the section of the parking spur where camping vehicles (cars, vans, recreational vehicles, truck and trailer combinations, and so forth) are parked. These definitions are important because the scoping and technical provisions vary based on the specific part of the parking spur being addressed. Figure 60 shows the parts of a parking spur. The surface of the entire parking spur must be firm and stable as explained in the section on *Surfaces for ORARs*.



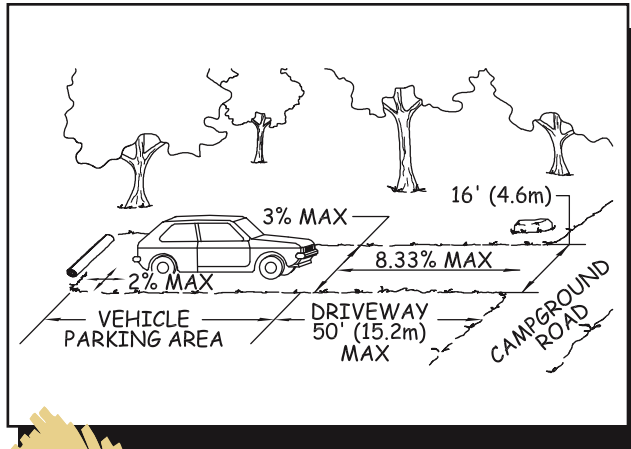

Figure 60—The components of a campground parking spur.

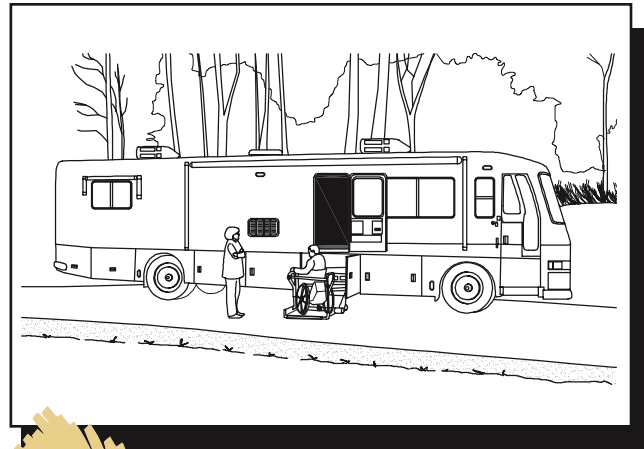

Figure 61—An accessible RV with a lift.

Each vehicle parking area that is adjacent to a camp living area must be at least 16 feet (4.8 meters) wide but the FSORAG also requires that some parking areas be 20 feet (6 meters) wide.

The 16-foot (4.8-meter) width is the same as the standard width for an accessible parking stall for vans. An exception allows this width to be reduced to a minimum of 13 feet (4 meters), the width of an accessible parking space for cars, where a condition for departure exists. Where the parking area can't be made at least 13 feet (4 meters) wide because of a condition for departure, a second exception allows construction of a narrower parking area. However, designers are strongly encouraged to avoid constructing parking areas less than 13 feet (4 meters) wide.

A 16-foot- (4.8-meter-) wide parking area will accommodate cars, vans, and the majority of recreational vehicles (RVs) and trailers. However, an area that is 20 feet (6 meters) wide is required for full-size accessible RVs (figure 61) and trailers. This width is required to accommodate lifts, ramps, and other assistive equipment that allow RV owners to enter, exit, and move around all sides of the vehicle. The dimensions are based on a 8-foot- (2.4-meter-) wide vehicle, an 8-foot- (2.4-meter-) wide

space on the passenger side for operation of the lift or ramp with room to maneuver, and a 4-foot- (1.2-meter-) wide clear space along the driver's side.

To maximize accessibility while protecting the natural environment, only a limited number of vehicle parking areas must be 20 feet (6-meter-) wide vehicle parking areas is based on the total number of camping units provided in the campground (table 2).

Table 2—The number of 6-meter- (20-foot-) wide vehicle parking areas required in campgrounds of different sizes.

Number of camping units	Minimum number of accessible recreational vehicle and trailer parking areas
1 to 25	1
26 to 75	2
76 to 100	3
101 to 200	4
201 to 300	5
301 to 500	6
501 to 1,000	1 percent of total
1,001 and over	10, plus 1 for each 100 over 1,000

For example, if a 50-unit campground is being designed, a minimum of two vehicle parking areas must be 20 feet (6 meters) wide. The vehicle parking areas for the remaining 48 camping units must be at least 16 feet (4.8 meters) wide, with the exceptions noted above. This is similar to the approach used by ABAAS for accessible hotel rooms. The minimum required number of accessible rooms is proportional to the total number of rooms in the hotel. Similarly, the minimum number of accessible vehicle parking areas is proportional to the total number of vehicle parking areas.

The running slope of a parking spur driveway may be up to 1:12 (8.33 percent) for 50 feet (15 meters). An exception for areas of steeper terrain permits the running slope to be up to 1:10 (10 percent) for 30 feet (9 meters). In alterations of existing developed campgrounds only, a second exception permits the running slope to be up to 1:10 (10 percent) for distances up to 50 feet (15 meters) if the first exception cannot be met because of a condition for departure. This second exception does not apply to new construction.

The cross slope of a parking spur driveway must not exceed 1:33 (3 percent). An exception permits a cross slope up to 1:20 (5 percent) if needed for proper drainage and to provide a transition from the campground road to the vehicle parking area. For example, if a back-in parking spur is adjacent to an interior campground road that has a running slope steeper than 1:20 (5 percent), the driveway may have to have a steeper cross slope to make the transition from the running slope of the road to the relatively level vehicle parking area (figure 62).



DESIGN TIP—

**Parking for walk-in camping units**

For walk-in camping units, the required parking space width depends on whether the parking space is part of the camping unit or is a separate parking area. If the walk-in unit has its own parking spur, then it falls under the FSORAG parking spur requirements, and the parking area should be 16 feet (4.8 meters) wide as required by the vehicle parking area provision, or less if an exception applies. If the parking space is part of a group parking area such as a 10-car parking lot that is provided for 8 walk-in units, the whole parking area must meet the requirements of ABAAS sections F208 and 502. For the parking lot above, nine parking spaces would be 10 feet (3 meters) wide, and one would be 16 feet (4.8 meters) wide.

52

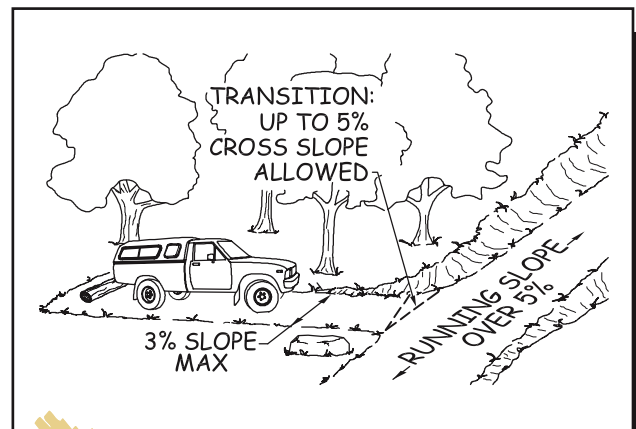

Figure 62—The transition from a parking spur driveway to a campground road.

There are separate slope requirements for vehicle parking areas and driveways because of the different functions they perform. The slope of the vehicle parking area can't exceed 1:50 (2 percent) in any direction. However, where needed for proper drainage, an exception permits the slope to be up to 1:33 (3 percent) in any direction.



## DESIGN TIP—

***Pedestrians in the driveway***

Do the running and cross slope requirements sound familiar? They should! Because people move around the vehicle parking areas and along the driveways, parking spurs also have to be able to function as ORARs, so the requirements are similar to those for ORARs.

The running and cross slopes of the driveway, even in alterations, should be kept as gentle as possible so that vehicles and people can easily and safely navigate into and out of the camping unit, erosion is minimized, and road design and construction standards are met.

***Parking Spurs for Double Camp Units***—If a double parking spur is provided to accommodate two accessible recreational vehicles at a double camping unit, the total width of the combined vehicle parking area may be reduced from 40 feet (12 meters) to 36 feet (11 meters).



## DESIGN TIP—

***How long should the parking area be?***

The FSORAG has requirements for parking space or spur width, but not length. So, how long should each parking area spur be? That depends on the type of vehicle that is expected to use the parking area and the terrain. Ordinary parking lots are normally designed with 20-foot (6-meter) long parking spaces to accommodate passenger vehicles, so parking areas should be at least 20 feet (6 meters) long. A large trailer with a towing vehicle could be up to

*Continued* ↪

60 feet (18.3 meters) long and a bus-style RV could be up to 45 feet (13.7 meters) long.

Some campgrounds include parking spurs of various lengths. This limits campsite choices for campers with larger trailers or RVs, but also keeps costs lower and minimizes hardened surfaces and ground disturbance, especially on difficult terrain. Campers with larger trailers and RVs appreciate having information available online and at the campground about the length of parking spaces.

***Camp Unit Identification***—People need to know whether they will be able to use a particular campsite. This can be accomplished differently, depending on the type of campground. If all camping units are accessible, no posted identification is required.

If some—but not all—campsites are accessible and campers choose their campsite when they arrive at the campground, accessible camping units must be identified at the campground's entrance kiosk, fee station, bulletin board, or registration area. Accessible campsites should not be individually signed as accessible with the International Symbol of Accessibility, because that tends to stigmatize and draw attention to those sites. Instead, include the following type of statement on the registration information sign: *Units 2, 4, 6, and 10 are accessible. If no one in your group needs accessible campsites, please fill these units last.* Forests that have been using this type of statement on the registration sign report that visitors generally have complied.

If some—but not all—campsites are accessible and each camping unit is assigned through a reservation system that contains accessibility information or if the campsite is assigned by someone who can provide information about each unit, accessibility information doesn't have

to be posted. The accessible units should be assigned as needed to individuals with disabilities. The accessible campsites that are not assigned to persons with disabilities should be filled last, keeping them available in case they are needed.

**Camp Unit Tent Pads and Tent Platforms**—At least 20 percent of the total number of tent pads or tent platforms provided in a developed recreation area must meet the requirements below and be connected to the other major constructed features at the recreation area by an ORAR.

A minimum 48-inch (1,220-millimeter) **clear floor** or **ground space** must be provided on all sides of the tent on tent pads and platforms that are required to be accessible. An exception permits this width to be reduced to a minimum of 36 inches (915 millimeters) where a condition for departure exists. When tent pads or platforms are provided in developed recreation areas, the clear space must be adjacent to the ORAR, but it may not overlap the ORAR.

There is no minimum tent pad size because the types of tents commonly used in developed recreation areas and in GFAs vary widely in different parts of the country and even in different parts of a single district. For example, at a campground near a wilderness access point, small tents may be used. Large family tents may be common at a more developed campground with numerous constructed features for campers.

Local campground managers are the best source of information about the size of tents commonly used in an area. Adding the 48-inch (1,220-millimeter) or 36-inch (915-millimeter) clear space to the size of a typical tent will determine the minimum size of tent pads and platforms for that campground. Designers may want to provide a range of tent pad or platform sizes to accommodate a variety of tents.

In GFAs, 5 percent of the total number of tent pads or platforms must meet the requirements, but connection to an ORAR isn't required. Because most facilities provided in GFAs are for resource protection rather than for visitor convenience, the requirements are reduced to minimize alteration of the site and setting, while integrating accessibility.

For instance, it isn't unusual to find six or seven tents close together in a GFA. Typically, the spaces allotted for these tents are about 10 by 12 feet (3 by 3.6 meters), which would easily accommodate a 5- by 8-foot (1.5- by 2.4-meter) tent. An accessible pad for the same size tent with a 4-foot (1.2-meter) clear space all around would need to be at least 13 by 16 feet (4 by 4.8 meters). If all tent spaces were required to meet the FSORAG's technical provisions, a significantly larger area would be affected by the tent pads.

The **slope of an accessible tent pad or platform** can't exceed 1:50 (2 percent) in any direction. An exception permits the slope to be up to 1:33 (3 percent) maximum where needed for proper drainage. Figure 63 shows the required dimensions and slopes for tent pads and platforms.

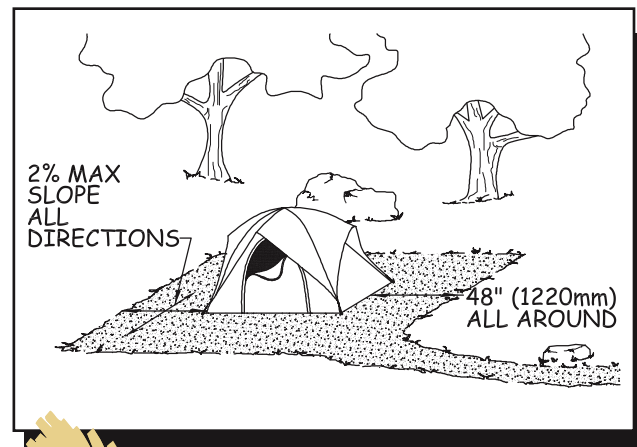

Figure 63—The requirements for a tent pad.



The **surface of an accessible tent pad or platform** must be firm and stable, be able to accommodate the use of tent stakes or other devices to secure the tent, and should be of a material that is appropriate for the level of development and setting. An exemption to the surfacing provision is allowed where a condition for departure exists.

The FSORAG doesn't require **edge protection** on tent platforms. However, if designers and managers determine that edge protection is needed for safety or other reasons, it must be at least 3 inches (75 millimeters) high. If edge protection is provided, it must not be placed where it would block access to the platform.

Accessible tent platforms are sometimes at ground level and sometimes above ground level. The ORAR should connect to ground-level tent platforms at ground level. For above-grade platforms, there are two choices. The ORAR can either ramp up to platform level, or it can end adjacent to the tent platform at 17 to 19 inches (430 to 485 millimeters) lower than the platform. This height is suitable for transferring from a wheelchair to the platform. Figure 64 shows a solution for providing an accessible tent platform in a highly developed campground.

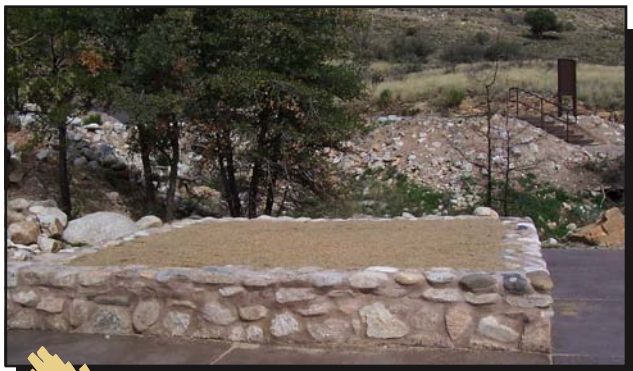

Figure 64—A tent platform in a highly developed campground at the Coronado National Forest.

*Fire Rings, Fireplaces, and Wood Stoves*—Although these features are addressed in separate sections of the FSORAG, they are discussed together here because their provisions are quite similar. Where fire rings and wood stoves are provided, each one must meet the requirements explained below. When fire rings and wood stoves are provided in developed recreation areas, an ORAR must connect them to the other major constructed features at the recreation area. An ORAR isn't required for fire rings, fireplaces, and wood stoves in GFAs.

The fire-building surface within a fire ring must be a minimum of 9 inches (230 millimeters) above the floor or ground surface. This matches the low side reach range in ABAAS. An exemption from the 9-inch (230-millimeter) height requirement is allowed where a condition for departure exists. This exception is included particularly for fire rings provided in GFAs and wilderness areas.

For example, in the Boundary Waters Canoe Area Wilderness, some fire rings created by users at popular campsites are allowed to remain (rather than being dismantled) to reduce the chance that campfires might become wildfires. Often these fire rings are simple circles of rocks that can be considered temporary structures appropriate in the wilderness setting. A fire-building surface 9 inches (230 millimeters) above the ground would require higher sides and a permanent structure that would be inappropriate in a wilderness setting.

Some outdoor fireplaces and custom-built fire rings have a wall around the fire-building area, perhaps built out of bricks or mortared stone. In addition to the requirement for a fire-building surface that is at least 9 inches (230 millimeters) above the ground or floor, the distance a person would have to reach across the wall and down to the fire-building surface cannot exceed 24 inches (610 millimeters). Figures 65 and 66 illustrate this requirement.

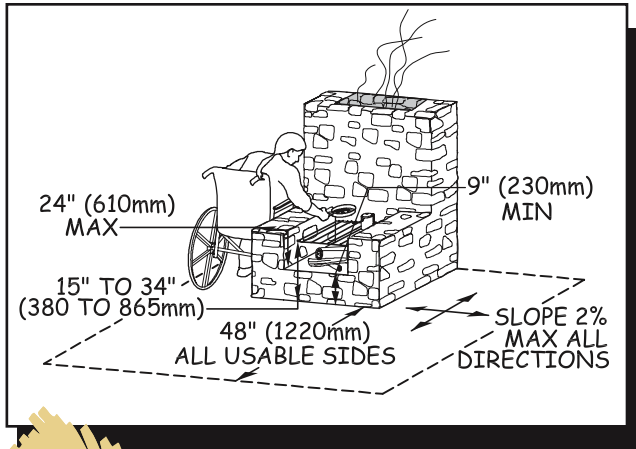

Figure 65—The height, clear space, and reach range requirements for an outdoor fireplace.

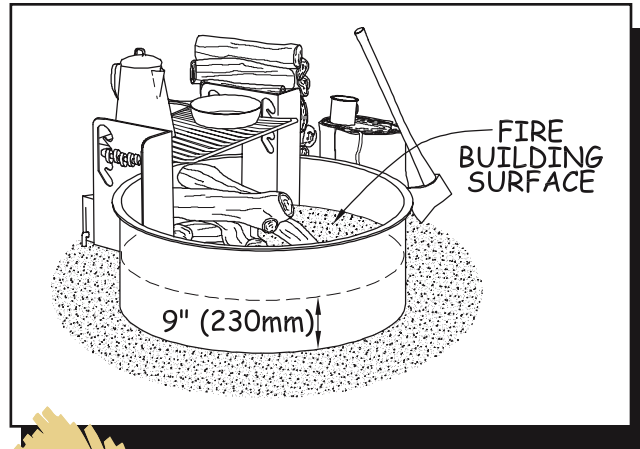

Figure 67—The height and reach requirements for manufactured steel fire rings.

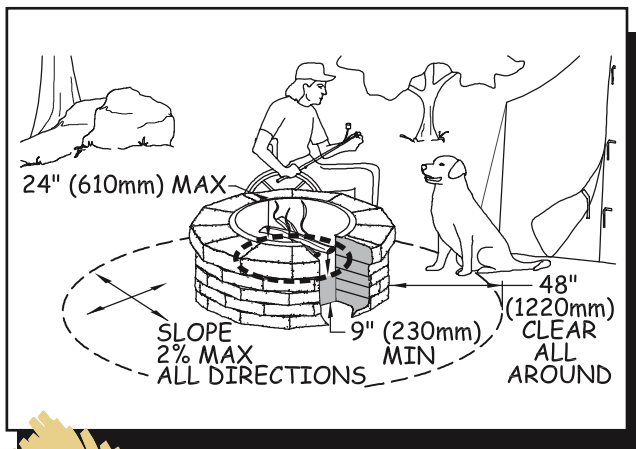

Figure 66—The height and reach requirements for custom fire rings.

This provision normally doesn't affect standard, commercially manufactured fire rings that are common in developed campgrounds, such as the fire ring shown in figure 67. The material used to fabricate commercial fire rings usually is not very thick or wide, so the reach to the fire-building surface is normally less than 24 inches (610 millimeters).

All usable portions of a fire ring, fireplace, or wood stove must have a clear floor or ground space that extends at least 48 inches (1,220 millimeters) out from the ring or stove and is at least 48 inches (1,220 millimeters) wide. An exception allows this space to be reduced to 36 inches

(915 millimeters) minimum where a condition for departure exists. The clear space must be adjacent to the ORAR, but it may not overlap the ORAR. The clear space is required for safety so that someone isn't forced to get too close to the heat or fire and risk getting burned.

The slope of the clear floor or ground space around a fire ring, fireplace, or wood stove may not exceed 1:50 (2 percent) in any direction. Where required for proper drainage, an exception permits the slope to be up to 1:33 (3 percent) in any direction. The surface of the clear floor or ground space must be firm and stable. Exemptions from the slope and surface requirements for fire rings, fireplaces, and wood stoves are allowed where a condition for departure exists. The exceptions are particularly relevant for fire rings provided in GFAs.

Controls and operating mechanisms for a wood stove must comply with the provisions for reach ranges and operability specified in ABAAS sections 308 and 309 and explained in *Reach Ranges and Operability Requirements*.

**Utilities**—Electricity, drinking water, sewer, and other utilities that are provided in developed recreation areas must meet the requirements explained below.

Controls and operating mechanisms for utilities must comply with the provisions for reach ranges and operability specified in ABAAS sections 308 and 309 that are explained in *Reach Ranges and Operability Requirements*. Sewage hookups don't have to comply with the reach ranges of ABAAS section 308 or operation requirements of section 309, but the slope and surface requirements must still be met.

A clear floor or ground space of at least 30 by 48 inches (760 by 1,220 millimeters), oriented for front or side approach to all usable sides of utilities must be provided, except at water hydrants, which have their own requirements that are explained below. The clear floor or ground space around utilities may overlap adjacent clear spaces. Figures 68 and 69 illustrate this requirement.

The slope of the clear spaces required at utilities and water hydrants can't exceed 1:50 (2 percent) in any direction. The slope can be up to 1:33 (3 percent) maximum in any direction, if required for proper drainage. The surface of the clear space must be firm and stable and of a material that is appropriate to the level of development and setting.

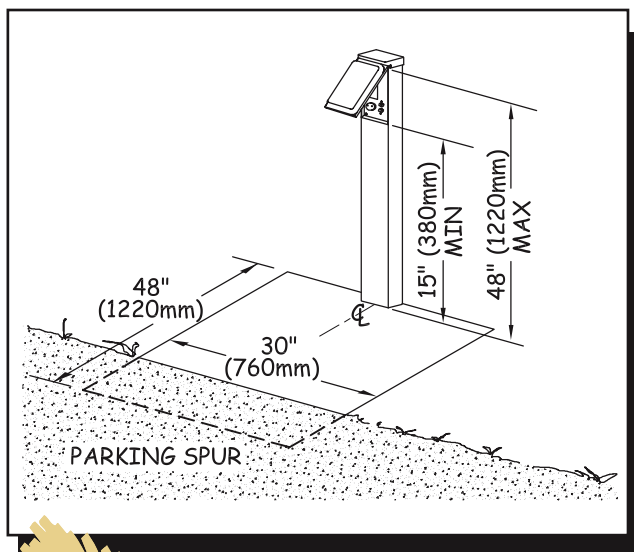

Figure 68—The requirements for campground utilities are illustrated by this electrical connection.

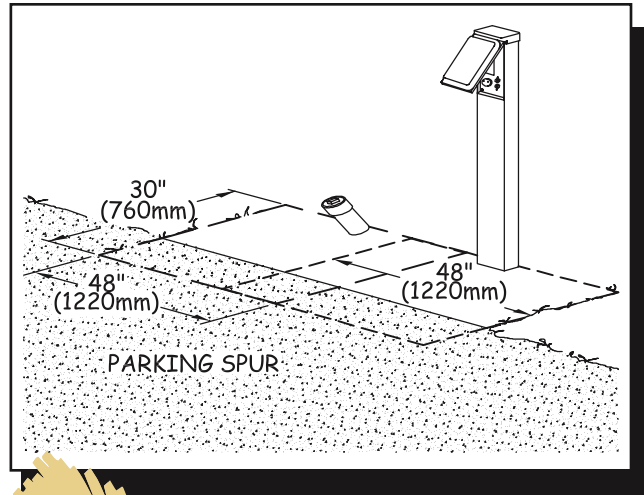

Figure 69—The clear space for utilities can overlap at campsites.

**Water Hydrants**—Water hydrants are the outdoor devices from which people obtain drinking water, and include water faucets on posts and hand pumps. They must be between 28 inches (710 millimeters) and 36 inches (915 millimeters) above the ground or floor surface on the edge of a clear space that is at least 60 by 60 inches (1,525 by 1,525 millimeters). This permits a forward or side approach to the hydrant and allows enough room for someone in a wheelchair to turn around and leave.

If the hydrant is an unusual design with the handle and spout on different sides of the post, be sure that people can access both sides. The required clear space must be adjacent to the ORAR, but it may not overlap the ORAR. In addition, if drainage grates are provided, the openings in the grate must comply with the ORAR provision for openings. Figure 70 illustrates these requirements.

While the controls for a hydrant must comply with the provisions for reach ranges and operability specified in ABAAS sections 308 and 309 and explained in the section on Reach Ranges and Operability Requirements, hand pumps are exempt from this requirement. Standard hand pumps require a force greater than 5 pounds (2.2

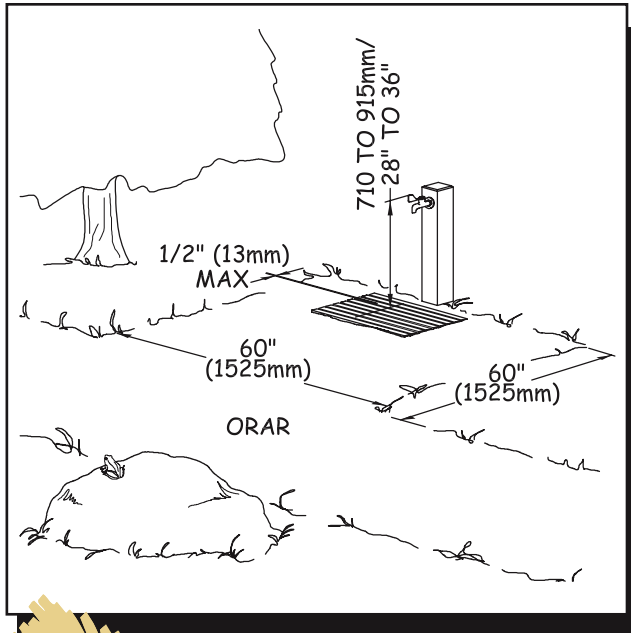

Figure 70—The requirements for water hydrants.



Figure 71—This accessible handpump was developed by the Missoula Technology and Development Center.

newtons) and a long reach to operate. Until hand pumps are available that can meet the accessibility standard for operating controls, while adequately accessing the water supply, hand pump operating controls are exempt from this requirement.

The Forest Service's Technology and Development program has produced an accessible hand pump that can be used where the well is 40 feet (12 meters) deep or less. This pump should be used for new or replacement shallow-well installations where the accessible pump meets the technical specifications for the water supply. Information about the commercially manufactured accessible hand pump (figure 71) is available at: <http://www.fs.fed.us/t-d/programs/eng/handpump.btm> (Username: t-d Password: t-d). The tech tip, *New Accessible Handpump for Campgrounds*, also has information about the commercially manufactured accessible hand-pump. The tech tip is available on the Internet at: <http://www.fs.fed.us/t-d/pubs/htmlpubs/btm05712311/> (Username: t-d, Password: t-d).

**Utility Sinks**—A utility sink is deeper than a standard restroom basin or kitchen sink and can be used to clean large pots or equipment. Usually, utility sinks are provided only in highly developed recreation areas. At least one of each type of sink provided in each accessible room or space and at least 5 percent of the total number of utility sinks must comply with the requirements explained below.

Clear floor or ground space that is at least 30 inches (760 millimeters) by at least 48 inches (1,220 millimeters) must be provided at each accessible utility sink and be oriented for either a forward or side approach. These requirements are identical to the requirements in ABAAS sections 305.3 and 305.5. The clear space at the utility sink must be connected to an ORAR, but it can't overlap the ORAR. The slope of the clear floor or ground space can't exceed 1:50 (2 percent) in any direction, although an exception permits a slope up to 1:33 (3 percent) in any direction where needed for proper drainage. The surface of the clear floor or ground space must be firm and stable and of a material that is appropriate for the setting and level of development.



The height of the counter or rim surrounding the sink can't be more than 34 inches (865 millimeters) above the ground or floor space. The bottom of the bowl must be at least 15 inches (380 millimeters) above the ground or floor space. If hot water is provided, the pipes should be wrapped or shielded to prevent someone from accidentally touching the hot pipes. Sink controls and operating mechanisms must comply with the provisions for reach ranges and operability specified in ABAAS sections 308 and 309 and explained in *Reach Ranges and Operability Requirements*. Figure 72 illustrates these requirements.

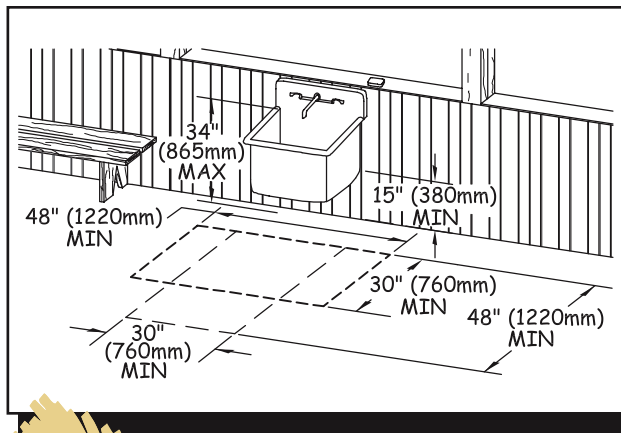

Figure 72—The requirements for utility sinks.

### Other Constructed Features

Section 6 of the FSORAG addresses miscellaneous constructed features that may be provided in developed recreation areas and other recreation areas. These features include **benches, trash and recycling containers, viewing areas at overlooks, telescopes and periscopes, storage facilities for assistive devices, pit toilets in GFAs, warming huts, outdoor rinsing showers, and signs.**

**Benches**—Each bench that is provided in a developed recreation area must meet the provisions explained below

and be connected to the other major features of the recreation area by an ORAR. Benches that are provided in GFAs must meet the requirements, but they do not have to be connected to an ORAR.

### DESIGN TIP—

#### ***What about inside benches?***

Remember that the FSORAG covers outdoor recreation areas. The FSORAG requirements for benches don't apply to benches inside buildings. Built-in benches that are provided inside buildings are covered by ABAAS sections F221.2.1.1, F21.2.2, and 903, even if the buildings are in recreation areas.

The front edge of the bench seat must be between 17 and 19 inches (430 and 485 millimeters) above the ground or floor space. When more than one bench is provided in a common area such as a campground amphitheater or a scenic overlook, at least half of the benches must have back support that runs the full length of the bench.

One armrest must be provided on at least half of the benches with backrests. Consider the visitors who will use a particular area when deciding where to locate an armrest. For people who have difficulty standing up from a seated position, having an armrest can be helpful. Armrests on both ends of the bench could prevent a person using a wheelchair from being able to transfer onto the bench.

A compromise design is a bench with a backrest and one armrest placed in the middle of the bench. Figure 73 shows a bench that meets these requirements. Another option is to place a single armrest on the end of the bench farthest from the clear floor or ground space.

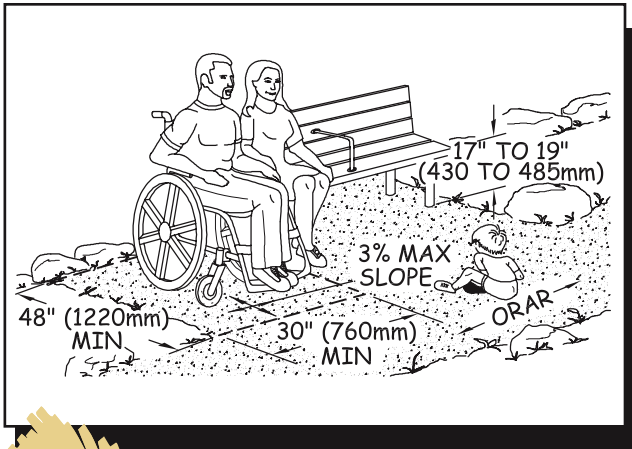

Figure 73—The requirements for benches.

All parts of the bench must be able to withstand 250 pounds (1,112 newtons) applied vertically or horizontally at any point of the seat, fastener, mounting device, or supporting structure. This requirement is the same as the ABAAS requirement for bench strength in section 903.6.

A clear floor or ground space that is 30 by 48 inches (760 by 1,220 millimeters) must be provided adjacent to one end of each bench. This clear space can't overlap the ORAR. The slope of the clear floor or ground space can't exceed 1:33 (3 percent) in any direction. The surface must be firm and stable and made from a material that is appropriate to the setting and level of development. Exceptions to the slope and surface requirements are allowed if a condition for departure exists. These exceptions may be particularly applicable to benches provided in GFAs.

#### *Trash, Recycling, and Other Essential Containers—*

Many recreation areas have trash and recycling containers for visitor convenience, to protect the environment, or to discourage visits to the area by wild animals. Some campgrounds also provide bear-resistant food storage containers. Each container must meet the requirements explained below. When containers are provided in a developed recreation area, they must be connected to the other major features of the recreation area by an ORAR. Connection to an ORAR isn't required for containers provided in GFAs.

In a multibin container, only half the containers for each purpose must meet the accessibility requirements. For example, if a trash container has four separate compartments, only two of the compartments are required to meet the technical provisions. But all the bins of a recycling container with four separate bins to collect four different types of recyclable materials must meet the requirements. Figure 74 illustrates these requirements.

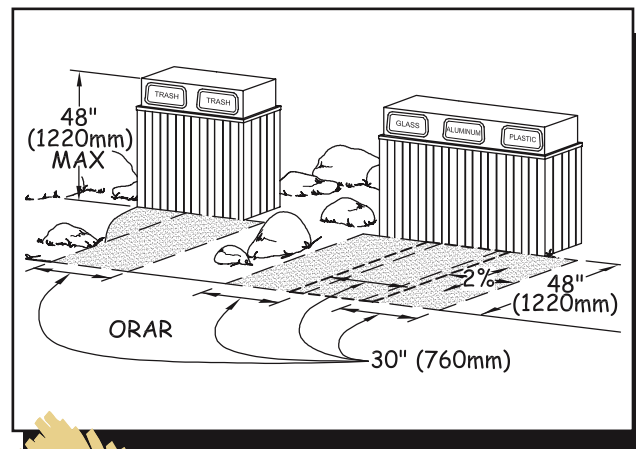

Figure 74—The requirements for trash and recycling containers.

A 30- by 48-inch (760- by 1,220-millimeter) clear floor or ground space positioned for a forward or side approach is required at each container. The clear space must be adjacent to the ORAR, but it can't overlap. The slope of the clear space must not be steeper than 1:50 (2 percent) in any direction. A 1:33 (3 percent) slope is allowed where necessary for drainage. The surface must be firm and stable and made from a material that is consistent with the setting and level of development. The slope, surface conditions, and ORAR connection requirements don't have to be met for containers in GFAs if there is a condition for departure.

Controls and operating mechanisms for containers must comply with the provisions for reach ranges and operability specified in ABAAS sections 308 and 309 and explained in *Reach Ranges and Operability Requirements*.

An exception is allowed for lids and controls designed to deter large animals, such as grizzly bears (figure 75). Large animals, especially bears, pose a real threat to humans when they become accustomed to wandering through developed recreation areas in search of food. Containers equipped with accessible controls and operating mechanisms are easy targets for hungry bears. The potential for unpleasant encounters between humans and bears increases if bears regard these containers as outdoor buffets. Containers in recreation areas where bears and other large animals pose a risk to humans don't have to comply with accessibility provisions for operating controls until containers are available that do so while meeting the requirements for bear control.

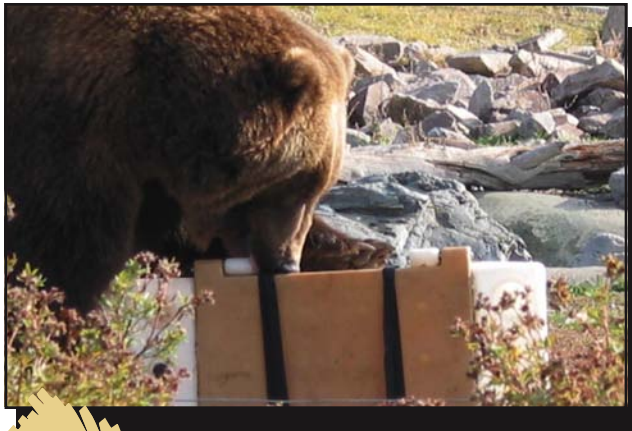

Figure 75—Grizzly bears have the power and persistence to get food that is not secured properly.

**Viewing Areas at Overlooks**—Overlooks and viewing areas are designed and constructed to provide an unobstructed view of a vista or of a specific point of interest, such as the view of a mountain range, a valley, a waterfall, or a unique geologic formation (figure 76). Because overlooks and viewing areas are a destination point, they must be accessible so all visitors can enjoy the viewing opportunities. Each viewing area at an overlook is required to comply with the requirements explained below.



Figure 76—The overlook on the San Juan Skyway scenic byway in Colorado allows all visitors to enjoy the view.

When viewing areas are provided in developed recreation settings, they must be located along an ORAR that connects to the other major features at the area. Connection to an ORAR isn't required where viewing areas are provided in GFAs. If several viewing areas are provided, at least one unrestricted viewing opportunity for each distinct point of interest must be accessible.

An unrestricted viewing opportunity means a clear field of vision toward the vista or point of interest that extends from 32 to 51 inches (815 to 1,295 millimeters) above the floor or ground of the viewing area. Compliance with the requirements isn't mandatory where a condition for departure exists.

Viewing areas often are adjacent to hazardous dropoffs. Barriers such as walls, safety rails, or signs installed for safety reasons could block views. This doesn't mean that either accessibility or safety measures should be ignored! Designers need to consider different ways of providing for safety without blocking the view. For example, see-through panels or screened openings could be installed, or the designer may be able to build the overlook with a series of tiers or terraces (figure 77). The placement

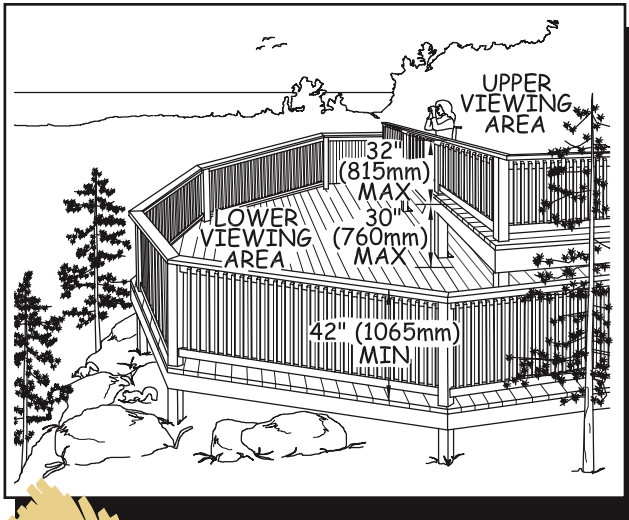

Figure 77—This overlook has two levels so the railing can be lower at the upper viewing area.

of interpretive signs may also help create a barrier to keep people back from the edge of the overlook without encroaching on the 32- to 51-inch (815- to 1,295-millimeter) clear field of vision (figure 78).

62

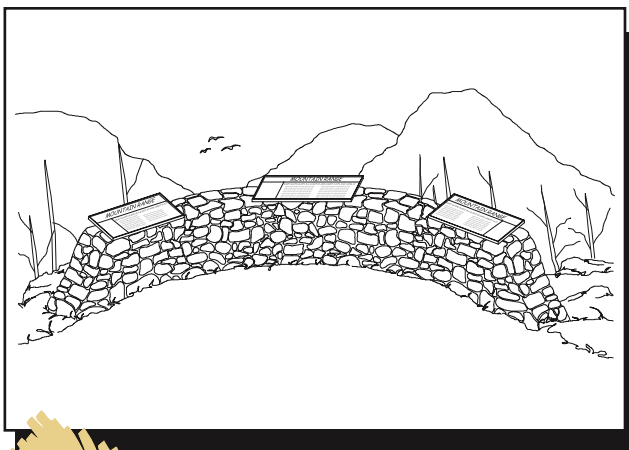

Figure 78—Signs placed to create a barrier at an overlook.



### DESIGN TIP— **Railing design**

Providing safety while maximizing viewing opportunities is a challenge for those designing a railing or structure adjacent to a dropoff. It's possible to design two viewing levels (see figure 77), where the lower level would be less than 30 inches (760 millimeters) below the upper level.

With this design, a tall guardrail isn't required for the upper level. At the upper level, where the visitors generally approach the viewpoint, a low railing or wall can permit good visibility. The lower viewing level would have a tall guardrail meeting the International Building Code requirements. This lower level provides the "catch" area for the primary level.

If the area or structure doesn't lend itself to a two-level approach, a see-through 42-inch- (1,065-millimeter-) high railing may work (figure 79). The vertical rails should be placed so that a 4-inch (100-millimeter) sphere can't pass through them. Visibility through this type of railing is excellent. The eye level of most adults seated in a wheelchair is above 42 inches (1,065 millimeters), and children sitting on the deck can enjoy the view through the rails.

The importance of vertical rather than horizontal rails can't be overemphasized. When children see horizontal rails, they regard them as an inviting ladder that encourages them to climb. The guardrail can't protect them from a fall when they do so (figure 80).





Figure 79—This railing is safe, meets code requirements, and provides a great view, even when you look through the rails.

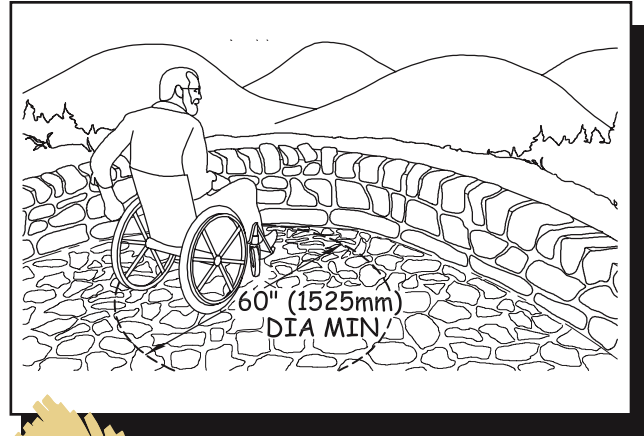

Figure 81—The requirements for turning space at a viewing area.



Figure 80—Caution: railings with horizontal rails make an inviting ladder for small children.

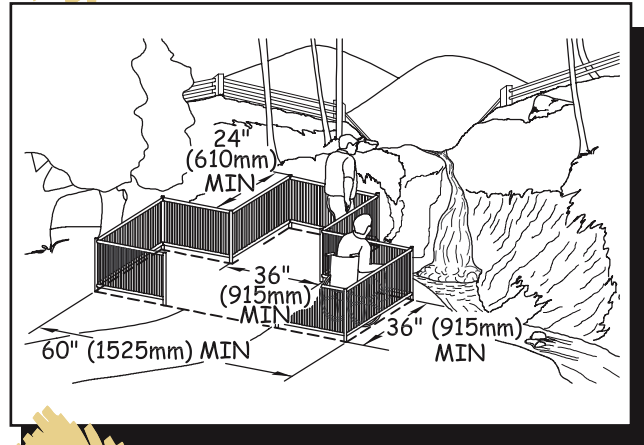

Figure 82—The requirements for a “T” turning space at a viewing area.

At least one turning space at least 60 inches (1,525 millimeters) in diameter (figure 81) or “T” shaped with a minimum 60- by 36-inch (1,525- by 915-millimeter) “arm” and a minimum 36-inch- (915-millimeter-) wide by 24-inch- (610-millimeter-) long “base” (figure 82) must be provided at each accessible viewing area. This requirement is the same as ABAAS section 304.3. This space allows someone using a wheelchair or other assistive device to approach and move about the viewing area. The slope must not exceed 1:50 (2 percent) in any direction, but may be up to 1:33 (3 percent) in any direction

where required for proper drainage. The surface should be firm and stable and of a material that is appropriate to the setting and level of development. Exemptions are allowed from slope or surface provisions where a condition for departure exists.

**Telescopes and Periscopes**—Viewing areas are sometimes equipped with mounted telescopes or periscopes to provide the visitor with a closer view of a point of interest. If one telescope or periscope is provided in a developed recreation area, it must meet the requirements explained below and be usable from both standing and seated positions. If several are provided, at least 20 percent of them must comply with the provisions of

this section. Accessible telescopes and periscopes must be connected to an ORAR. There is no exception to the ORAR requirement because telescopes and periscopes aren't provided in GFAs.

Controls and operating mechanisms for accessible telescopes and periscopes must comply with the provisions for reach ranges and operability specified in ABAAS sections 308 and 309 and explained in *Reach Ranges and Operability Requirements*. The eyepiece of an accessible telescope or periscope must be usable from a seated position for viewing each point of interest. Many existing telescopes and periscopes are only usable from a standing position. Requiring the eyepieces of accessible telescopes and periscopes to be usable from a seated position will provide the widest range of viewing opportunities not only for seated individuals, but also for children and people of short stature. Alternatives for meeting this requirement include an adjustable scope mount, a swivel seat, or installation of duplicate scopes mounted at different heights. Figure 83 shows one way to configure an accessible telescope area.

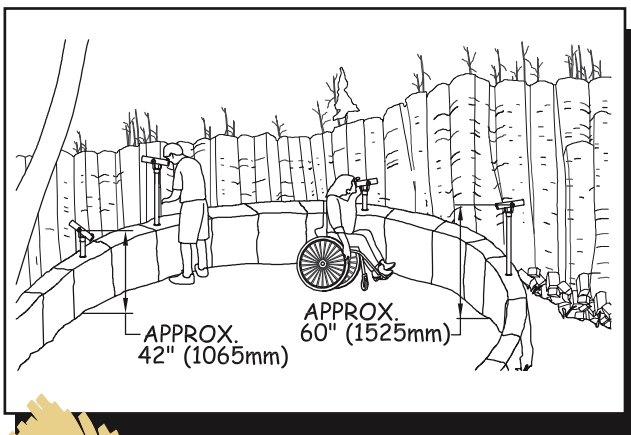

Figure 83—The requirements for telescopes and periscopes.

Turning space must be provided at all accessible telescopes and periscopes so that someone using a wheelchair or other assistive device can approach and move around them. This maneuvering space must be at least

60 inches (1,525 millimeters) in diameter (see figure 81) or “T” shaped with a minimum 60- by 36-inch (1,525- by 915-millimeter) “arm” and a minimum 36-inch- (915-millimeter-) wide by 24-inch- (610-millimeter-) long “base” (figure 82). This requirement is the same as ABAAS section 304.3.

The slope of the maneuvering space can't exceed 1:50 (2 percent). However, a slope of up to 1:33 (3 percent) in any direction is allowed where required for proper drainage. The surface of the maneuvering space must be firm and stable, and made from a material that is appropriate to the level of development and setting.

**Storage Facilities for Assistive Devices**—Storage for assistive devices is required when individuals using a wheelchair or other assistive device must transfer to another device or vehicle to participate in the services or programs offered at a developed recreation area. For instance, at ski areas, people who use wheelchairs typically transfer to some type of adaptive ski equipment. They need to store their wheelchairs safely while they're out skiing. Each storage facility for assistive devices such as wheelchairs must meet the requirements explained below, and must be connected to the other major features of the recreation area by an ORAR.

Storage facilities designed for assistive devices must be at least 38 inches (965 millimeters) high, at least 28 inches (710 millimeters) wide, and at least 40 inches (1,015 millimeters) long. A clear floor or ground space that is 30 by 48 inches (760 by 1,220 millimeters) and positioned for a side approach must be provided in compliance with ABAAS section 305.3. The slope of this clear space can't exceed 1:33 (3 percent) in any direction, and the surface must be firm, stable, and made from a material that is appropriate to the setting and level of development. Compliance with the surface provision isn't mandatory if a condition for departure exists.

Controls and operating mechanisms must comply with the provisions for reach ranges and operability requirements specified in ABAAS sections 308 and 309 and explained in *Reach Ranges and Operability Requirements*.

**Pit Toilets in General Forest Areas**—Generally, pit toilets are located in remote, undeveloped areas. They are provided primarily for resource protection, rather than for visitor convenience and comfort. Pit toilets are primitive outhouses that may consist simply of a hole dug in the ground covered by a toilet riser (figure 84). The pit toilet riser may or may not be surrounded by walls and may or may not have a roof. Pit toilets may be permanent installations or they may be moved from one location to another as the hole is filled or the area has become overused. Waste disposal in pit toilets may be directly into the ground (pit) or may include moldering or composting processes.



Figure 84—A fiberglass riser for a pit toilet in the Boundary Waters Canoe Area.

Designers should not confuse pit toilets provided in general forest areas with toilets provided in developed recreation areas. Pit toilets are only provided in general forest areas and are NEVER appropriate in developed recreation areas!



#### DESIGN TIP—

***It's not a pit toilet if it's not in a general forest area.***

Vault toilets, flush toilets, and composting toilets are all common in developed recreation areas. They are not considered pit toilets and they must meet the ABAAS requirements for toilet buildings. Regardless of the waste disposal system or design of the building, toilet buildings that aren't in GFAs and that have one riser must comply with section 603 of the ABAAS requirements for toilet and bathing rooms. Toilet buildings that aren't in GFAs and that have multiple risers must comply with the requirements of section 604 of the ABAAS. Designers should be careful not to confuse the requirements for toilet stalls with those for single riser toilet rooms. Each toilet building in a developed recreation area also must comply with the requirements for grab bars, controls, and dispensers.

If pit toilets are provided in GFAs, each one must meet the requirements described below. Pit toilets in GFAs don't have to be connected to ORARs.

The design of pit toilets varies widely depending on the setting, the amount of expected use, and the system used to manage the waste. If an accessible pit toilet has walls, a floor, a door, or a roof, these components must comply with the appropriate provisions of the ABAAS. If the pit toilet has a riser and toilet seat, the total height of that seat and the riser it rests on must be 17 to 19 inches (430 to 485 millimeters) above the ground or floor.

If there are sturdy walls around the pit toilet riser, standard riser dimensions, placement, and grab bars are required as shown in ABAAS sections 603, 604, and 609. Grab bar size, strength, finish, and position requirements are explained in *Grab Bars*. Grab bar location requirements for pit toilets are explained below.

Grab bars must comply with the reach ranges required in ABAAS section 308 and explained in Reach Ranges and Operability Requirements. As required in ABAAS section 604.5, grab bars for toilets must be installed in a horizontal position, 33 to 36 inches (840 to 915 millimeters) above the finished floor, measured to the top of the gripping surface.

The grab bar beside the riser must be at least 42 inches (1,065 millimeters) long, located no more than 12 inches (305 millimeters) from the wall behind the toilet, and extend at least 54 inches (1,370 millimeters) from the rear wall. The grab bar behind the riser must be at least 36 inches (915 millimeters) long and extend from the centerline of the water closet at least 12 inches (305 millimeters) on the side closest to the side wall grab bar and at least 24 inches (610 millimeters) on the other side (figure 85).

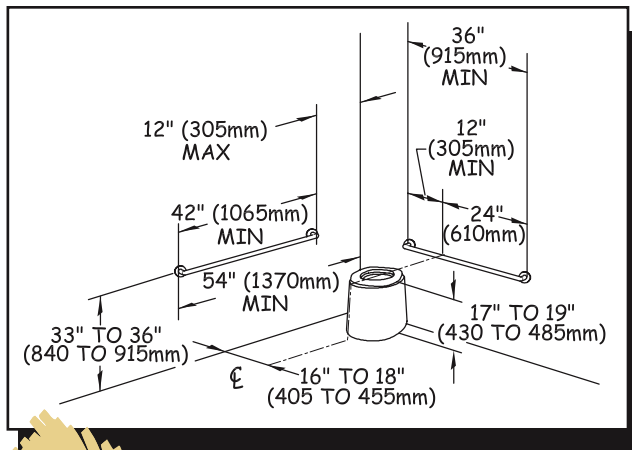

Figure 85—The requirements for grab bars in pit toilets.

For pit toilets enclosed by walls, the back of the riser must be against the wall behind the riser. A clear floor space that is at least 60 inches (1,525 millimeters) wide and 56 inches (1,420 millimeters) deep is required around the toilet. If there is a condition for departure, the space can be reduced to 56 by 48 inches (1,420 by 1,220 millimeters).

Of the required width of clear floor space, only 16 to 18 inches (405 to 455 millimeters) can be on one side of the centerline of the riser, and the rest must be on the other side. Turning space of at least 60 inches (1,525 millimeters) in diameter or “T” shaped with a minimum 60- by 36-inch (1,525- by 915-millimeter) “arm” and a minimum 36-inch- (915-millimeter-) wide by 24-inch- (610-millimeter-) long “base” is also required. Portions of the turning space may overlap the toilet clear floor space or be located directly outside the entrance (figure 86).

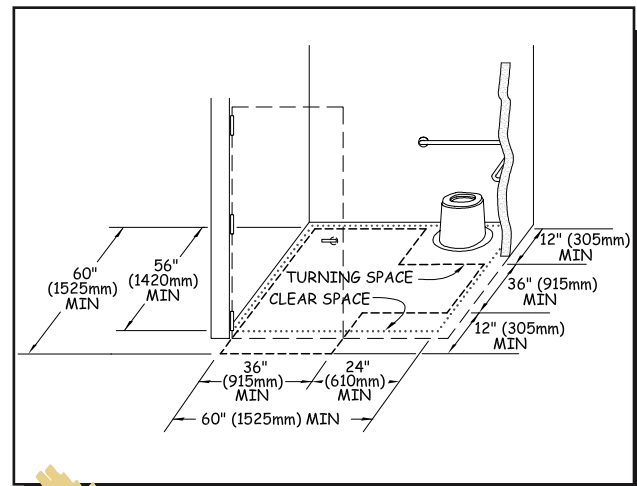

Figure 86—The requirements for a “T” turning space in a pit toilet.

If walls are provided, doorways or wall openings that provide entrance to the toilet must have a minimum clear width of 32 inches (815 millimeters), in compliance with ABAAS section 404.2.3. Door swings can’t obstruct the clear floor space inside the pit toilet. Doors that open out or slide are space-efficient ways to provide the required interior clear space. Door hardware such as handles, pulls, latches, and locks must comply with the provisions for reach ranges and operability specified in ABAAS sections 308 and 309 and explained in *Reach Ranges and Operability Requirements*.



If the pit toilet has lightweight privacy screens or has no walls, the riser should have vertical or nearly vertical sides, a flat area on each side of the seat that is about 3 inches (75 millimeters) wide, and a seat cover that also functions as a back rest. For safety, grab bars must not be mounted on lightweight privacy screens that won't support 250 pounds (1,112 newtons). A clear floor or ground space that is at least 60 inches (1,525 millimeters) wide and 56 inches (1,420 millimeters) deep is required.

Of the required width of clear floor space, only 16 to 18 inches (405 to 455 millimeters) can be on one side of the centerline of the riser, and the rest must be on the other side. The depth of the clear space is measured from the back of the riser and extends in front of the riser (figure 87). If there is a condition for departure, the space can be reduced to 56 by 48 inches (1,420 by 1,220 millimeters).

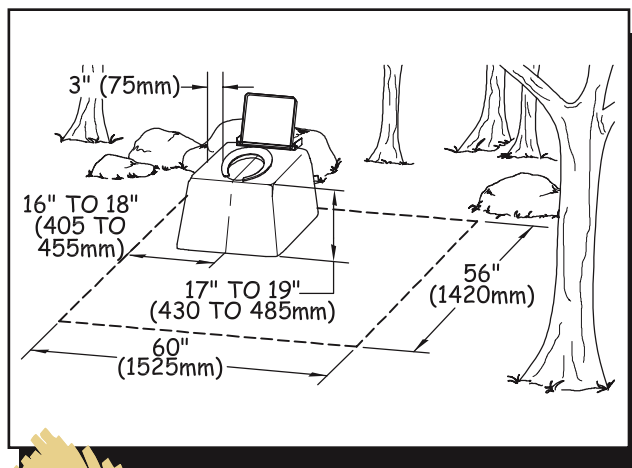

Figure 87—The requirements for clear space at an unenclosed toilet.

Whether the pit toilet has walls or not, the slope of the turning space and the clear floor or ground space generally can't exceed 1:50 (2 percent) in any direction. The slope can be up to 1:33 (3 percent) in any direction where required for proper drainage. The surface must be firm and stable and made from a material that is appropriate to the setting and level of development. Slope or surface requirements don't have to be met where a condition for departure exists.



#### CONSTRUCTION TIP—

##### **Privacy screens**

Lightweight privacy screens are sometimes provided for pit toilets in remote general forest areas. Screens may be provided in areas that have heavy visitor use but where walls or sturdier enclosures would significantly change the recreational setting or adversely impact significant natural features, or where it is difficult and expensive to pack in conventional construction materials. These screens may be made from tent fabric or other thin materials, and have only enough structural strength to stay upright.

Because privacy screens don't have enough strength to support a 250-pound (1,112-newton) load on grab bars, grab bars should never be attached to them. Imagine the consequences if a screen and the grab bar attached to it fell over when a person tried to use it to transfer to a toilet! Instead of attaching grab bars to screens, the screens should be positioned outside the clear area required for unenclosed toilets, so people can use the toilet without needing grab bars.

The entrance to each pit toilet should be at ground level. If this isn't feasible, because of the toilet's operation and maintenance requirements, a trail complying with Forest Service Trail Accessibility Guidelines (FSTAG) section 7.3 must be provided between the ground and toilet entrance. FSTAG section 7.0 explains the requirements for trails to "associated constructed features" such as pit toilets. If the pit toilet must be located above the ground and a trail isn't feasible because of a condition for departure, steps are permitted—but only as a last resort.

Composting and moldering toilets have a "basement" area where waste is processed. The need to service the area under the riser may make it difficult to provide a

ground-level entrance to the toilet. In other areas, surface bedrock, permafrost, or other ground conditions make it tough to dig a pit. Table 3 will help designers avoid steps at toilet entries and may trigger other creative ideas for accessible entries.

Table 3—Pit toilet entry decision aid.

<b>Are steps needed for this pit toilet?</b>	Is maintenance access to a waste processing area below the riser needed? Is digging a pit into the ground impractical?	➔	<b>NO</b> Provide ground level entrance.
	↓ <b>YES</b>		
	Have all options for a ground level entrance been exhausted?	➔	<b>NO</b> Look at the site again. Is excavation, placement of the building on a slope, or addition of fill material at the entrance feasible to allow a ground-level entrance?
	↓ <b>YES</b>		
	As an absolute last resort, provide steps in accordance with FSORAG section 6.6.9.		

The need for steps may be eliminated altogether if enough time is spent on site selection. For instance, a sloping site may allow the maintenance “basement” to be accessed from the downhill side, while providing a ground-level entrance to the toilet on the uphill side (figure 88).

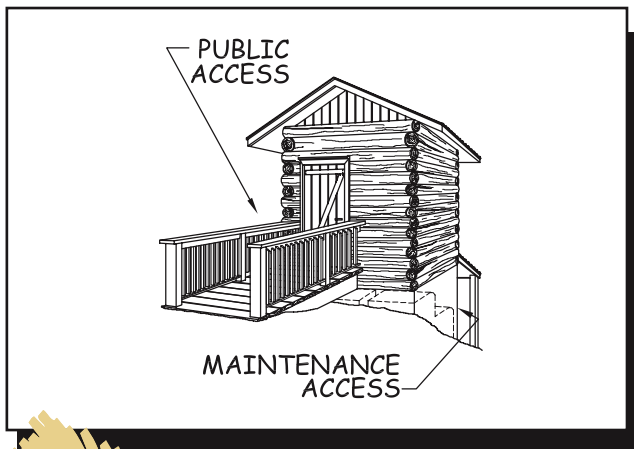

Figure 88—The two accesses to an uphill-downhill composting toilet.



**DESIGN TIP—**

***Toilet steps should be a design solution of last resort.***

If steps are used, keep in mind that a person using a wheelchair will have to get out of the wheelchair and transfer up the steps onto the pit toilet floor. Since pit toilet floors are seldom cleaned regularly, it is easy to imagine how dirty and disgusting this would be. Avoid steps if at all possible! Think about it—would you want to make that trip?

If steps can't be avoided, they must meet specific requirements that aren't the same as standard building code requirements. The treads must be at least 14 inches (355 millimeters) deep and 36 inches (915 millimeters) wide and no more than 9 inches (230 millimeters) high.

*Continued* ➔

Practically speaking, the deeper the tread, the shallower the rise should be for comfortable use. With a 14-inch (355-millimeter) tread, a 6-inch (150-millimeter) riser is preferable, even though up to 9 inches (230 millimeters) is allowed. A level, clear ground space that is 30 by 48 inches (760 by 1,220 millimeters) must be provided along one unobstructed side of the steps.

One of the steps must be 17 to 19 inches (430 to 485 millimeters) above the clear ground space so that a person in a wheelchair can transfer onto it. Single steps are hazards that should be avoided; at least two steps, but preferably three, should be used. Although it's not mentioned in the FSORAG, be sure that a door swing doesn't block access from the step someone uses when transferring from a wheelchair.

**Warming Huts**—Permanent, fully enclosed buildings are not warming huts. Permanent buildings with walls, roof, and a door must meet all the applicable requirements of the ABAAS. Warming huts are temporary or partially enclosed spaces used intermittently for brief periods as protection from the weather. If amenities such as tables or wood stoves are provided in warming huts, they must meet the requirements of FSORAG sections 1 through 5 explained above. In addition, a turning space at least 60 inches (1,525 millimeters) in diameter (see figure 81) or “T” shaped with a minimum 60- by 36-inch (1,525- by 915-millimeter) “arm” and a minimum 36-inch (915-millimeter-) wide by 24-inch (610-millimeter-) long “base” (figure 82) must be provided inside the hut. This requirement is the same as ABAAS section 304.3.

Warming huts in developed recreation areas must be connected to other major features of the recreation area by an ORAR. If the floor of the hut is above ground level, the ORAR can either ramp up to floor level, or it can end

adjacent to the tent platform 17 to 19 inches (430 to 485 millimeters) lower than the platform. This height allows someone to transfer from a wheelchair to the platform. Warming huts provided in GFAs don't have to be connected to an ORAR.

**Outdoor Rinsing Showers**—Even though the ABAAS sections 607, 608, and 609 cover showers, outdoor rinsing showers are specifically addressed in the FSORAG because the ABAAS description and provisions are intended for indoor facilities. Outdoor showers permit people to rinse off sand, dirt, and debris. They are not intended for bathing. They generally don't offer privacy and people usually are not permitted to disrobe.

Two types of outdoor rinsing showers are addressed: a low shower, accessible to someone in a seated position, and a high shower accessible to someone who is standing. If two or more outdoor rinsing showers are provided in a developed recreation area, at least one must be a low shower meeting the requirements explained below and at least one must be a high shower meeting the requirements explained below. If only one outdoor rinsing shower is provided, it must meet the requirements and be usable from both a seated and standing position. Accessible outdoor rinsing showers must be connected to the other major features of the recreation area by an ORAR. There is no exception to the ORAR because outdoor rinsing showers aren't typically found in GFAs.

For a low outdoor rinsing shower, a fixed shower head must be mounted between 48 and 54 inches (1,220 and 1,370 millimeters) above the ground or floor, the same as the ABAAS requirement for accessible indoor showers. For a high outdoor rinsing shower, a fixed shower head must be mounted at least 72 inches (1,830 millimeters) above the ground or floor. A hand-held shower spray unit complying with ABAAS section 608.6 may be used in place of a fixed shower head. Hand-held showerheads are vulnerable to vandalism and breakage, so they are

probably not a good design choice for most developed recreation areas. A more durable choice would be to mount low and high showerheads on one pole or wall.

Grab bars for accessible outdoor rinsing showers are not used for transfers, but are essential for stability in a wet environment. Three types of grab bars are addressed in this section: vertical, circular, and horizontal. Vertical and circular grab bars are used with showers mounted on posts. Horizontal grab bars are used with shower heads mounted on walls. Every outdoor rinsing shower must have at least one vertical, circular, or horizontal grab bar.

Grab bars for accessible outdoor rinsing showers must comply with the standard reach ranges of ABAAS section 308 that are explained in *Reach Ranges and Operability Requirements*. Grab bar size, position, mounting requirements, and structural strength are explained in *Grab Bars*. The location requirements for grab bars at outdoor rinsing showers are explained below.

If a vertical grab bar is provided at a shower head mounted on a post, the grab bar must be installed directly under the shower head. It must extend from no more than 33 inches (840 millimeters) above the floor or ground to within 3 inches (75 millimeters) of the shower head (figure 89).

If the shower head is mounted on a post, a circular grab bar may be used in place of a vertical grab bar. The grab bar must surround the usable part of the post and be installed under the shower head between 33 and 36 inches (840 and 915 millimeters) above the ground or floor (figure 90).

If a shower head is mounted on a wall, a horizontal grab bar must be provided. The grab bar must be installed under the shower head between 33 and 36 inches (840 and 915 millimeters) above the ground or floor and extend at least 18 inches (455 millimeters) in both directions from the center line of the shower head (figure 91).

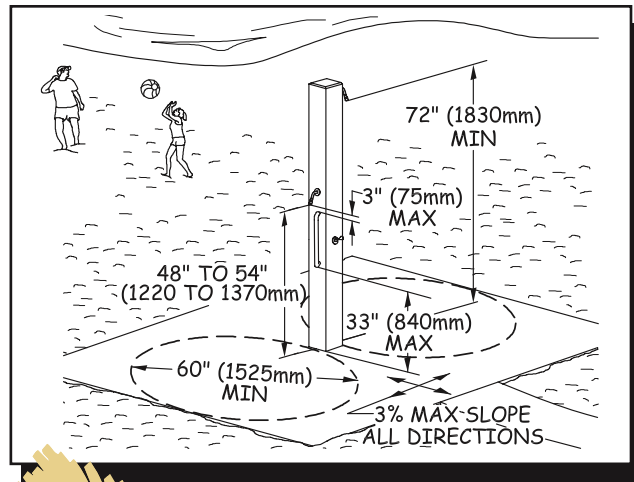

Figure 89—The requirements for a vertical grab bar.

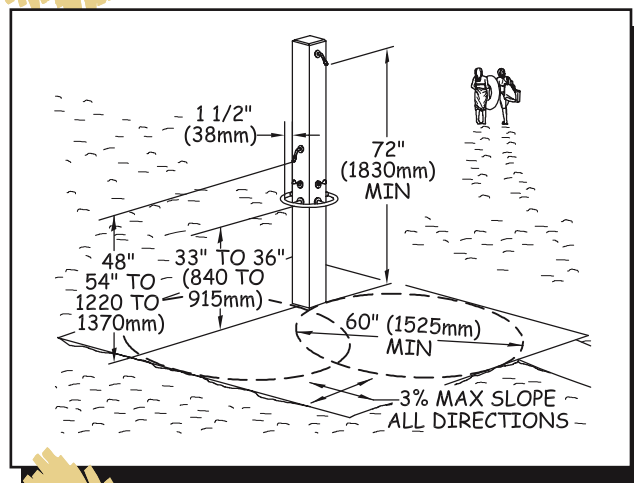

Figure 90—The requirements for a circular grab bar.

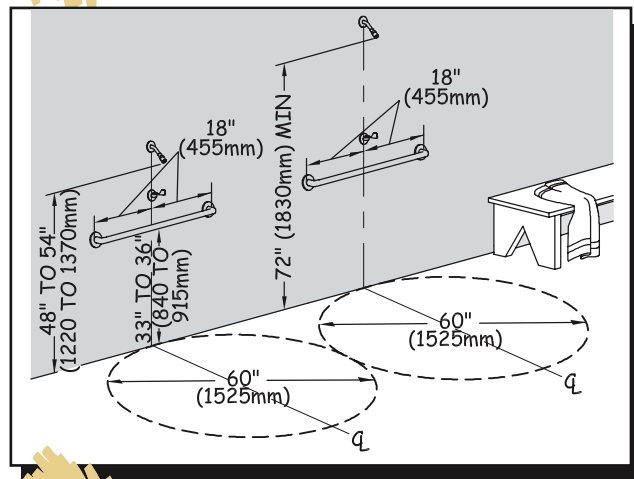

Figure 91—The requirements for horizontal grab bars.



Rinsing shower controls and operating mechanisms must comply with the provisions for reach ranges and operability specified in ABAAS sections 308 and 309 as explained in *Reach Ranges and Operability Requirements*. If self-closing controls are used, the controls must remain open for at least 10 seconds.

A clear floor or ground space at least 60 inches (1,525 millimeters) in diameter must be provided at each accessible outdoor rinsing shower. It must be located so that the water from the shower head is directed toward the center of the clear space. The slope of the clear space can't exceed 1:33 (3 percent) in any direction. The surface must be firm and stable and made from a material that is appropriate to the level of development and the setting.

**Signs**—Signs provide key information concerning the accessibility of programs and facilities. In accordance with ABAAS section 216, the International Symbol of Accessibility must be posted at six places:

- Accessible parking spaces in developed parking lots with five or more parking spaces. Do not post the International Symbol of Accessibility at parking spurs provided at camping units or other individual accessible features.
- Accessible loading zones.
- Accessible restrooms and bathing facilities.
- At the main entrance to a building, with an arrow directing people to the closest accessible entrance, if the main entrance is not accessible.
- On the door to an accessible *Area of Refuge* inside multistory buildings.
- At an accessible means of egress out of a building.

The International Symbol of Accessibility can only be posted where all constructed features and areas comply with the ABAAS. Except for the requirement to post the word *VAN* on the parking sign at van accessible spaces, no words are required to be used with the symbol. If

words are used with the ISA, use *Accessible*; **do not** use *Handicapped*!

There is **NO** legal requirement on federally managed lands for International Symbol of Accessibility signs to be blue and white, even at parking spaces. If the International Symbol of Accessibility is used, it must be posted in accordance with ABAAS section 703.7, in high-contrast colors with a nonglare finish. A cream or pale yellow International Symbol of Accessibility on a brown background complies with this requirement and blends into an outdoor setting.

If you want the local law enforcement agency to be able to issue tickets for illegal parking at accessible parking spaces, the International Symbol of Accessibility must be displayed in blue and white and comply with the Manual of Uniform Traffic Control Devices (MUTCD) section 2B.39. Although their use is optional, the only approved colors for pavement markings designating accessible parking spaces are blue and white (MUTCD section 3B.18).

If a sign or kiosk has materials such as maps, brochures, fee envelopes, and so forth, the sign or kiosk must be designed to meet the standard accessible reach ranges in accordance with ABAAS section 308, as explained in *Reach Ranges and Operability Requirements*. Clear floor or ground spaces of 30 by 48 inches (760 by 1,220 millimeters) must be provided to allow a forward or side approach.

Post the appropriate international symbols where various modes of adaptive equipment are available, such as TTY (teletypewriter), sign language interpreters, assistive listening systems, and so forth (figures 92 through 101).

If you have questions about applying any of the above information, please contact your region's recreation accessibility coordinator. Current contact information is available on the Forest Service's internal computer

network at: <http://fsweb.mtdc.wo.fs.fed.us/toolbox/acc/documents/coord.htm>.



Figure 92—Information



Figure 93—International Symbol of Accessibility



Figure 94—Teletypewriter (frequently abbreviated as TTY)



Figure 95—Telephone with volume control



Figure 96—Video or film is closed caption



Figure 97—Audio description available



Figure 98—Assistive listening system available



Figure 99—Sign language interpretation available



Figure 100—Large-print (18-point) materials available



Figure 101—Materials available in Braille

Figures 92 to 101—International symbols indicating accessibility.



## Applying the Forest Service Trails Accessibility Guidelines

The first step in applying the Forest Service Trails Accessibility Guidelines (FSTAG) is to know when and where compliance is required. Section 7.0 *General* and 7.1 *Extent of Application* state that the FSTAG applies to National Forest System trails within the boundaries of a National Forest that meet *all* these criteria:

- The trail is new or altered.
- It is designed for hiker or pedestrian use.
- It connects either directly to a trailhead or to a trail that is already accessible.

The FSTAG doesn't apply to existing trails unless there is a change in the original purpose, intent, or function for which the trail was designed—an alteration, in other words. It doesn't apply to trails designed for ATV, equestrian, or any other nonpedestrian use. The FSTAG uses the term *designed for biker/pedestrian use* in accordance with the Forest Service trail planning and management rules and National Trail Management Classes, which are also the Interagency Trail Data Standards. This information is available at: <http://www.fs.fed.us/r3/measures/TR.btm>.

The FSTAG doesn't prescribe different “levels of accessibility” based on trail class or any other grouping criteria. Following the same philosophy as the draft document on outdoor recreation developed by a regulatory negotiations committee of the Architectural and Transportation Barriers Compliance Board (Access Board), the FSTAG recognizes that a trail is either accessible or it is not. The FSTAG provides guidance for maximizing accessibility, while recognizing and protecting the unique characteristics of the natural setting, level of development, and purpose of each trail—through the use of conditions for departure from the guidelines and the related exceptions to the technical provisions, explained below.

As explained in the budget tip *Is cost an excuse?*, cost is not a valid reason for failing to make a trail accessible. In all likelihood, the FSTAG won't apply to most portions of existing primitive, long-distance trails, al-

though it may apply to segments that pass through developed areas. The FSTAG recognizes that there is no real benefit in making a newly constructed or altered trail in the backcountry accessible if the only way to get to it is by using an existing trail that isn't accessible and probably can't be made accessible. Application of the FSTAG will ensure that the full range of trail opportunities continues to be provided, from primitive long-distance trails to highly developed interpretive trails at popular scenic overlooks, providing hiking opportunities for everyone (figure 102).



Figure 102—Hiking is for everyone.

### Is It a Trail or an Outdoor Recreation Access Route?

An Outdoor Recreation Access Route (ORAR) is a continuous, unobstructed path designated for pedestrian use that connects pedestrian elements within a developed recreation area such as a picnic area, camping area, or trailhead. In contrast, a trail is defined by the 2002 Interagency Trail Standards as a linear route managed for human-powered, stock, or off-highway vehicle forms of transportation or for historic or heritage values. A trail is not an ORAR and is not subject to the requirements for

ORARs found in section 2.0 of the FSORAG. Accessible trails designed for pedestrian and hiker use have their own set of requirements that are described below.

## Understanding Trail Terminology

Although this guidebook tries to explain requirements in ordinary language, some terms are important to understanding how the FSTAG is applied. The terms aren't organized alphabetically, but are grouped so that it's easy to understand the distinctions between similar terms.

**Designed use** is the intended use that controls the geometric design of a trail and determines the level to which it should be maintained. There is only one designed use per trail or trail segment. Although the trail may be actively managed for more than one use, the designed use determines the technical specifications for the trail. Often, the designed use is the managed use that requires the highest level of development. For example, pack and saddle stock require higher and wider clearances than do hikers, so a trail managed for both foot travel and horse use probably would have a designed use of "pack and saddle" rather than "hiker/pedestrian." More information about trail design parameters for the different designed uses is in *USFS Trail Design Parameters*, available at: [http://www.fs.fed.us/r3/measures/Inventory/trails%20files/National\\_Design\\_Parameters\\_1\\_31\\_2005.doc](http://www.fs.fed.us/r3/measures/Inventory/trails%20files/National_Design_Parameters_1_31_2005.doc).

**Managed use** includes the modes of travel that are actively managed and appropriate for a specific trail or area. This use reflects the management decision or intent to accommodate or encourage a specific type of trail use. Each trail or trail segment may have more than one managed use. For instance, a single trail may be managed for hiker and equestrian use in the summer and for cross-country skiing in the winter.

A **trailhead** is a site designed and developed by the Forest Service or other government agency, trail associations, trail maintaining clubs, trail partners, or other cooperators to provide a staging area for a trail. For purposes of the FSTAG, trailheads are not:

- Junctions between trails where there is no other access.
- Intersections where a trail crosses a road, or where users have developed an access point, but no improvements are provided by the Forest Service, trail associations, trail maintaining clubs, or trail partners, or other cooperators beyond minimal markers or modifications for health and safety.

**Trail classes** broadly organize trails by desired management characteristics and the level of development, based on forest plan direction. Trail classes take into account user preferences, the setting, protection of sensitive resources, and management activities. Trail classifications range from Trail Class 1 trails, which appear little different from animal paths and may disappear intermittently, to Trail Class 5 trails, which are usually wide, paved paths associated with highly developed environments. The FSTAG does not change Forest Service trail classes. More information about National Trail Management Classes, which are also the Interagency Trail Data Standards, is available at: [http://www.fs.fed.us/r3/measures/Inventory/trails%20files/Trail\\_Class\\_Matrix\\_1\\_31\\_2005.doc](http://www.fs.fed.us/r3/measures/Inventory/trails%20files/Trail_Class_Matrix_1_31_2005.doc).

**Setting** is the term used to describe the natural surroundings of a trail. On public lands outside rural and urban settings, the natural surroundings are usually the primary attraction for visitors. Improvements, such as trails, should not adversely affect the setting. For example, the design for a trail crossing a glacial boulder field must protect the geologic features. Accessibility is incorporated to the extent possible without fundamentally altering the natural environment. On the other hand, a trail designed for a wide open, relatively level area should follow the requirements of the FSTAG to the highest degree possible.



The following terms describe construction and maintenance work:

**Construction** is building a new trail or segment of trail where there was no trail before.

An **alteration** is a change in the original purpose, intent, or function for which the trail was designed.

**Maintenance** is the routine or periodic repair of existing trails or trail segments to restore them to the standards or conditions to which they were originally designed and built. Maintenance does not change the original purpose, intent, or function for which the trail was designed. Trail maintenance work isn't covered by the FSTAG. Maintenance includes:

- Removing debris and vegetation, such as fallen trees or broken branches on the trail; clearing the trail of encroaching brush or grasses; and removing rock slides.
- Maintaining trail tread, such as filling ruts, reshaping a trail bed, repairing a trail surface or washouts, installing riprap to retain cut and fill slopes, and constructing retaining walls or cribbing to support trail tread.
- Performing erosion control and drainage work, such as replacing or installing drainage dips or culverts, and realigning sections of trail to prevent erosion or to avoid boggy areas.
- Repairing or replacing deteriorated, damaged, or vandalized trail or trailhead structures or parts of structures, including sections of bridges, boardwalks, information kiosks, fencing and railings; painting; and removing graffiti.

While the FSTAG doesn't apply to maintenance, Forest Service policy is to improve accessibility wherever the opportunity arises. Resource managers are encouraged to improve accessibility on trails through trail maintenance

and repair activities. Every time a trail is maintained, there is an opportunity to improve access.

The term *reconstruction* is not used in Federal accessibility guidelines or the FSTAG, even though the term is used frequently by the trails community. For the purposes of the FSTAG, actions are categorized as construction, alteration, or maintenance.



#### TERMINOLOGY TIP—

#### ***What do you call a reroute?***

If trail work is grouped into only three categories—construction, alteration, and maintenance—what category do things like rerouting, reconstruction, and extensions of existing trails fall into? The key to answering this question is to concentrate first on the definition of *alteration*. Does the new work change the **original purpose, intent, or function** for which the trail was designed? In other words, will the trail serve a new destination? Will trail use change from, say, horses to hikers after you're done? Are you significantly changing the overall trail grade, width, or surface, or adding bridges where the trail used to ford streams or rivers? If the work doesn't fit the definition of *alteration*, it's either *construction* (if there was no trail there before) or *maintenance*.

## Trail Construction Techniques

There is plenty of good information available to help you build a trail, so we won't repeat it here. The *Trail Construction and Maintenance Notebook* includes practical techniques used to construct and maintain trails. It is

written for trail crew workers and is intended to be taken along on work projects. Numerous illustrations help explain the main points. It is available at: <http://www.fs.fed.us/eng/pubs/htmlpubs/btm04232825/> and <http://www.fhwa.dot.gov/environment/fspubs/00232839/>.

The report, *Wetland Trail Design and Construction*, describes materials and techniques used to construct trails in wetlands. It is written primarily for workers who are inexperienced in wetland trail construction, but it may also be helpful for experienced workers. Techniques suitable for wilderness settings and for more developed settings are included as well as lots of drawings to illustrate important points. It is available at: <http://www.fs.fed.us/t-d/pubs/htmlpubs/btm01232833/> (Username: t-d Password: t-d) and <http://www.fhwa.dot.gov/environment/fspubs/01232833/>.

76

Standard Forest Service trail specifications are available at: <http://www.fs.fed.us/database/acad/dev/trails/trails.btm>.

## Using the Conditions for Departure in the FSTAG

The FSTAG is based on the realities of the outdoor environment and recognizes that accessibility is not feasible everywhere because of limitations imposed by the natural terrain, existing vegetation, or other constraints. To ensure that the unique characteristics of the outdoor environment and trail recreation opportunities aren't compromised or fundamentally altered, exceptions and deviations from some technical provisions are permitted where certain circumstances, called *conditions for departure*, apply.

Section 7.1.1 of the FSTAG identifies four conditions for departure, and each is explained in more detail below. Circumstances under which exceptions can be made

based on the conditions for departure differ depending on the setting. Conditions for departure permit deviations from technical provisions only where there is a general exception or an exception detailed in the technical provision sections for a particular trail component. General exceptions and technical provisions for trail components will be explained later.

Conditions for departure are not a blanket exemption from all of the technical provisions for an entire trail! If a condition for departure occurs only on part of the trail or trail component, the technical provision applies everywhere else, and all technical provisions not affected by the condition for departure also apply. For example, if there is a trail between a stream containing endangered aquatic species and a cliff with petroglyphs on it, and you can't get the required trail width without either filling part of the stream or destroying some petroglyphs, an exception allows a narrower trail past the petroglyphs. One of the conditions for departure is "where compliance would cause substantial harm to cultural...or significant natural features." However, the other technical provisions still apply to that stretch of trail and the technical provision for width still applies to all the rest of the trail.

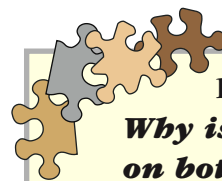

### DESIGN TIP—

#### ***Why is compliance required on both sides of a departure?***

Why is the trail required to comply with the accessibility provisions after terrain or an obstacle makes it necessary to depart from the guidelines? A person in a wheelchair would be blocked by the terrain or obstacle, so why make the trail accessible past that point?

Although accessible design is based on wheelchair dimensions, clear space, maneuvering room, and reach ranges, only 2 percent of people with disabili-

*Continued* ↪

ties use wheelchairs. The majority of people with mobility impairments don't use a wheelchair, but rely on crutches, canes, walkers, or braces. They may be able to get around or over an obstacle without too much difficulty. Although steep terrain may be difficult, it may be manageable for a limited distance.

Likewise, a person using a wheelchair might need assistance from companions to make it up a steep grade or to get over an obstacle, but once that difficulty is past, the individual can continue on the trail independently if the rest of the trail complies with the accessibility guidelines.

The conditions for departure cover all the important elements of a long-distance trail and the aspects that are considered when locating trail segments, but they should not be used as an excuse or loophole for failing to make trails accessible. Rather, they are to be used when all other design options have been thoroughly explored and a determination has been made that full compliance with the technical provisions would unacceptably alter the nature of the experience the visitor is seeking.

The four conditions for departure permit deviations from specific technical provisions where allowed by an exception. General examples are provided to help explain the intent of the conditions so that designers understand how to apply them according to the site-specific constraints and opportunities of their projects.

**1—Where compliance would cause substantial harm to cultural, historic, religious, or significant natural features or characteristics.**

A significant natural feature might be a large boulder or rocky outcrop, a unique tree or vegetation such as a giant sequoia grove (figure 103), or a body of water that is regarded as distinctive or important locally, regionally, or nationally. Significant natural features also could include

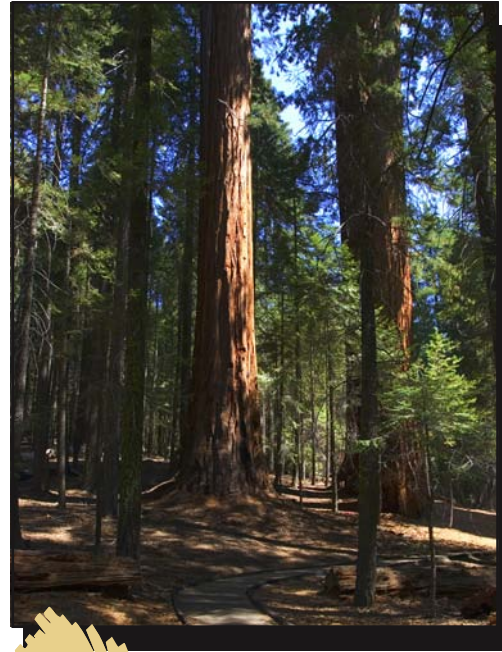

Figure 103—This giant sequoia grove is an example of a significant natural feature.

areas protected under Federal or State laws, such as habitat for threatened or endangered species, designated wetlands that could be threatened or destroyed by full compliance with the technical provisions, or areas where compliance would substantially harm natural habitat or vegetation.

Significant cultural features include areas such as archeological or other heritage sites, sacred lands, burial grounds and cemeteries, and tribal protected sites. Significant historical features include properties listed or eligible for listing on the National Register of Historic Places or other places of recognized historic value. Significant religious features include tribal sacred sites and other properties held sacred by an organized religion.

If the significant feature would be directly or indirectly altered, destroyed, or otherwise harmed by construction of the trail or trail element when making it accessible, this condition for departure would apply. Consider only the additional impacts of changes needed to provide accessibility. This condition for departure doesn't apply where substantial impact will result from construction of

a trail that is not accessible and only a little more impact is due to construction directly related to accessibility.

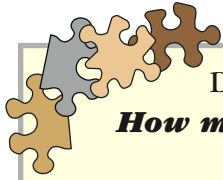

**DESIGN TIP—**

***How much harm is too much?***

The “harm” that is to be considered by this condition for departure is only the additional impact of increasing the width, reducing the trail grade or cross slope, or other change required for accessibility. For instance, there may be concern about the number of wildflowers being removed on cut and fill slopes for an accessible sidehill trail. The plants may be an uncommon species for which the surrounding river drainage and a nearby town are named. The trail construction will destroy most of the flowers as well as the seep-dampened hanging meadow that provides their habitat. This condition for departure wouldn't apply if 323 square feet (30 square meters) must be disturbed to make way for a trail that is not accessible and only another 75 square feet (7 square meters) must be disturbed to provide an accessible trail. The majority of the proposed damage to the wildflowers is not attributable to compliance with accessibility requirements. In this case, an alternate location should be selected for the trail.

78

**2—Where compliance would substantially change the physical or recreation setting or the trail class or designed use of the trail or trail segment or would not be consistent with the applicable forest land and resource management plan.**

Public lands provide a wide variety of recreational experiences, from highly developed areas that offer almost all the conveniences of home and plenty of opportunities to relax with family and friends, to wilderness areas that appear unchanged from primeval times and provide opportunities for individuals to experience primitive

and challenging conditions. The FSTAG recognizes the value of the full range of recreational opportunities by allowing exceptions where compliance with technical provisions would change the nature of the recreation opportunities or conflict with the resource management plan.

People using primitive trails, for example, experience the outdoor environment in a nearly natural state, with limited or no development. In these settings, people generally desire challenge and risk so they can use their outdoor and survival skills. Use of manufactured building materials or engineered construction techniques to comply with accessibility requirements could destroy the natural or undeveloped nature of the setting and change the visitor's experience. There is no requirement to dynamite obstacles or pave trails so they will be accessible if doing so would unacceptably change the character of the setting and the recreation opportunity.

Consider a trail intended to provide a rugged experience, such as a cross-country training trail with a steep grade or a fitness challenge course with abrupt and severe changes in elevation. If these trails were flattened out or otherwise constructed to comply with the technical provisions for accessible trails, they wouldn't provide the desired challenge for users. Trails that traverse boulders and rock outcroppings are another example. The purpose of these trails is to provide users with the opportunity to climb the rocks. To remove the obstacles along the way or reroute the trail around the rocks would destroy the purpose of the trail. The nature of the setting also may be compromised by actions such as widening a trail for an imported surface or removing ground vegetation from fragile or erosive soils.

**3—Where compliance would require construction methods or materials that are prohibited by Federal, State, or local law, other than State or local law whose sole purpose is to prohibit use by persons with disabilities.**



This condition for departure is best illustrated by example. For instance, federally designated wilderness areas prohibit use of mechanized equipment. If accessibility requirements can't be met with handtools, this condition for departure will apply in wilderness areas.

This condition for departure also may apply in areas:

- Where imported materials, such as soil stabilizers, are prohibited to maintain the integrity of the natural ecosystem or historic resources
- Such as designated wetlands or coastal areas where construction methods and materials are strictly limited
- Where Federal statutes such as the Wilderness Act, Endangered Species Act, or State and local law impose restrictions to address environmental concerns
- Where water crossings are restricted to safeguard aquatic features that are protected under Federal or State laws.

Local law has been included in this condition for departure to address situations where conservation easements or development programs have prohibited or restricted construction methods and practices.

On the other hand, under the Americans with Disabilities Act, State and local governments can't enact laws whose sole purpose is to prohibit use by people with disabilities. Therefore, that sort of law can't serve as a basis for deviation from the technical provisions in the FSTAG. For example, a local regulation that arbitrarily limits trail width to a dimension that wouldn't allow wheelchairs or other assistive devices to access a trail is not a justification for deviation from FSTAG requirements under this condition for departure.

#### **4—Where compliance would be impractical due to terrain or prevailing construction practices.**

The phrase “would be impractical” in this condition for departure refers to something that is not reasonable, rather than to something that is technically infeasible. This condition for departure applies when the effort and resources required to comply would be disproportionately high relative to the level of access created.



#### **DESIGN TIP— What's “feasible?”**

Using heavy construction equipment, it may be possible to provide a trail with a maximum 1:20 (5 percent) grade up a 1,500-foot (460-meter) mountain (figure 104). However, the trail would be about three times as long as under a traditional backcountry layout (figure 105), which could cause inappropriate environmental and visual impacts and more than triple the amount of ground disturbed. It wouldn't be feasible to construct an accessible trail in this situation.



Figure 104—A 5-percent grade trail on a steep hill.

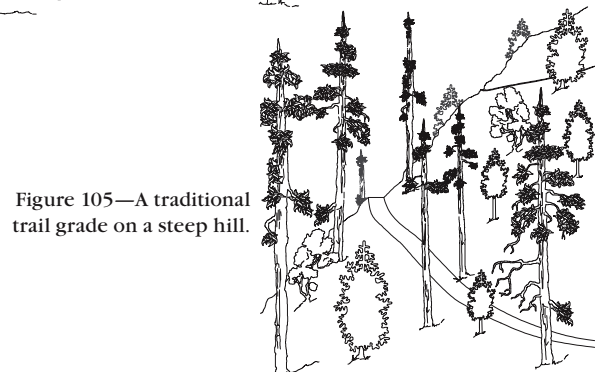

Figure 105—A traditional trail grade on a steep hill.

Trail construction practices vary greatly, from reliance on volunteer labor with handtools to professional construction using heavy, mechanized equipment. For alterations of existing trails, *prevailing construction practices* means the methods typically used for work on the trail. For new trails, the land manager determines the construction practices to be used on each trail. However, the choice of construction practice is determined primarily by available resources, such as machinery and skilled operators, and environmental conditions, such as soil type and depth, vegetation, and slope.

The intent of this condition for departure is to ensure that compliance with the technical provisions of the FSTAG does not require the use of construction practices that are beyond the skills and resources of the organization building the trail. This condition for departure is not intended to exempt the trail from the technical provisions of the FSTAG simply because a trail builder's favored construction practice includes the use of a large mechanical roller rather than a smaller vibrating plate or "wacker" type compactor. A contractor's or designer's preference for the larger equipment is not a "feasibility" issue.

This condition also may apply where construction methods for particularly difficult terrain or an obstacle require the use of equipment or methods other than that typically used throughout the length of the trail. In an area where small equipment or handtools are normally used to minimize impact on a sensitive adjacent stream, blasting might be required to remove a rock outcropping. Because blasting is outside the range of typical equipment and methods used, this condition for departure would apply.

## Using the General Exceptions in the FSTAG

Some public lands are reasonably well suited for hiking or pedestrian travel. Other public lands are rocky, soggy, excessively steep, or otherwise ill suited for foot traffic. Two general exceptions are provided in FSTAG section 7.1.2 to ensure that accessibility is provided where it will have the most benefit, be feasible, and provide a meaningful hiking opportunity. These general exceptions provide exemptions from the technical provisions for trails when environmental barriers are so severe or so numerous that a trail through an area can't be modified to meet the intent and objectives of an accessible hiking opportunity.

Where the general exceptions apply, the trail does not have to be accessible, except in two situations:

- A trail must always be accessible from either end to the first uncorrectable environmental barrier if the distance from the end of the trail to the barrier is more than 500 feet (152 meters) (figure 106).

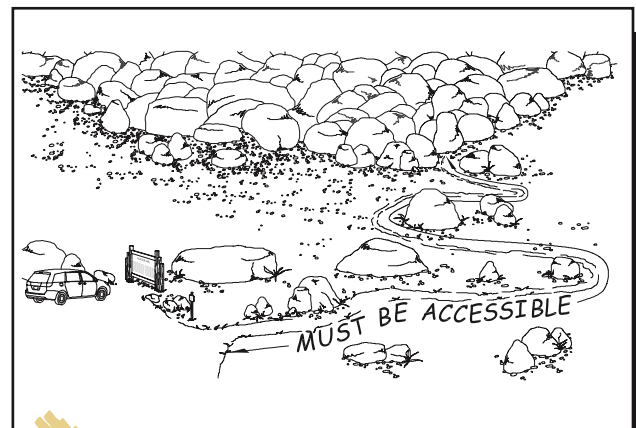

Figure 106—This trail section is over 500 feet (152 meters) long and must be accessible.

- A trail that goes past a prominent feature must always be accessible at least to the feature—no matter how far from the end of the trail—unless there’s an uncorrectable environmental barrier between the end of the trail and the prominent feature (figure 107).



Figure 107—There are no uncorrectable barriers between the end of this trail and the waterfall, so this section of the trail must be accessible.

Even if visitors can’t use the entire trail, they should be able to enjoy a short hike—especially if it includes a prominent feature (figure 108).



Figure 108—All hikers can enjoy this beautiful alpine lake.

A prominent feature is a natural, cultural, or historic feature along or adjacent to a trail that has national, regional, or local distinction or significance. It might be the focal point, main attraction, or destination of the trail or it may simply be an interesting secondary feature, such as a boulder outcrop, waterfall, grouping of old or unique trees, cultural or historic structure, a wildflower meadow, an area popular for wildlife viewing, or a vista.

**General Exception 1** addresses extreme environmental barriers (figure 109) that are effectively impassable and render the trail beyond unreachable for many people

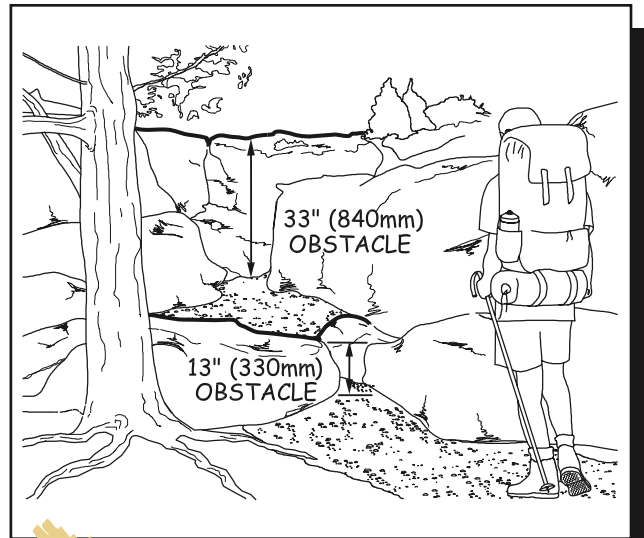

Figure 109—The 33-inch (840-millimeter) rock face is an example of an extreme environmental barrier.

with mobility limitations. It only applies when there are one or more conditions for departure **AND** at least one of the following limiting factors:

- The combination of trail grade and cross slope exceed 20 percent for more than 40 feet (12 meters).
- The surface is not firm and stable for 45 feet (13.7 meters) or more.

- The clear tread width is 18 inches (455 millimeters) or less for at least 20 feet (6 meters).
- A trail obstacle at least 30 inches (760 millimeters) high extends across the full width of the trail.

Remember that sections at the ends of a trail must always be accessible if they lead to prominent features or are more than 500 feet (152 meters) long before the first uncorrectable environmental barrier.

**General Exception 2** addresses trails with numerous environmental barriers that can't be eliminated, meaning that the trail would have no possibility of meeting the intent or objectives of an accessible hiking opportunity. Where one or more conditions for departure result in deviations from the technical provisions for more than 15 percent of the length of the trail, the trail is exempt from accessibility requirements. The percentage of trail affected by deviations is calculated by adding up the length of trail impacted by each deviation and dividing that distance by the total length of trail.

Consider the design for a new 1-mile- (1,600-meter-) long trail. Fifteen percent of 1 mile (1,600 meters) is 792 feet (240 meters). If all the lengths of trail where slope, width, or other requirements can't be met because of conditions for departure add up to more than 792 feet (240 meters) of trail, the technical provisions of FSTAG section 7.3 won't apply to most or all of the trail.

Remember that sections at the ends of a trail must always be accessible if they lead to prominent features or are more than 500 feet (152 meters) long before the first uncorrectable environmental barrier.

Some long-distance trails, such as the Continental Divide, Pacific Crest, Appalachian, or Florida National Scenic

Trails, or the Nee-Me-Poo National Historic Trail, span many districts or forests. For these trails, only the length of trail planned for construction or alteration within the current planning period is considered when figuring the 15 percent, not the entire length of the trail. This principle applies even if the planning period is several years long. Lengths of trail that are not connected but are covered by the same planning process should be considered separately, unless there is a special circumstance where several trails function together to access one attraction or serve one purpose. Connected sections of trail that will be constructed or altered over several years should be considered together.

## Documenting Decisions

If a determination is made that the FSTAG either doesn't apply to a trail or can't be met on some sections of the trail, section 7.1.3 of the FSTAG requires the determination to be documented and saved in the project file. The documentation doesn't have to be anything elaborate, and there's no required format. A single page stating how and why the determination was made, which conditions for departure and exceptions apply to what trail sections, the date, and the names of the people who made the decision is sufficient to show that the FSTAG was used at the onset of the project and that a good-faith effort was applied to the consideration of accessibility. A decision not to make a trail accessible is an important decision that will affect both current and future trail users and managers. The documentation is required to ensure that the decision can still be understood if the people involved are no longer available.





## Technical Provisions—How To Make a Hiker/Pedestrian Trail Accessible

Section 7.3 of the FSTAG explains the requirements for accessible trails, including trail **grade** and **cross slope**, **resting intervals**, **surfacing**, **clear tread width**, **passing spaces**, **tread obstacles**, **protruding objects**, **openings**, **edge protection**, and **signs**. All of these requirements are minimums. In the spirit and intent of universal design, designers are encouraged to meet the highest provisions wherever it is feasible, given the specific natural constraints of the environment, the level of development, and other managerial considerations. Trail puncheons and trail bridges are included in the Forest Service definition of trail constructed features, so they must be constructed to meet the same requirements. In the following sections, the term *trail* includes trail puncheons and trail bridges.

The building blocks for accessible design are mostly based on wheelchair dimensions, clear space, maneuvering room, and reach ranges found in the ABAAS. This is because the dimensions, multiple moving surface contact points and wheels of a wheelchair are usually the most difficult to accommodate. If a person who uses a wheelchair can use a trail, most other people can, too.

Technical provisions for trails are explained below. An Overview of the FSTAG Implementation Process and an Overview Chart of the FSTAG Implementation Process follow the technical provisions.

### Grade and Cross Slope for Trails

Trail grades and cross slopes must meet the requirements explained below. Recognizing that steeper terrain makes it difficult to achieve flat grades everywhere, and that people are able to handle steeper slopes for short distances, several options are provided to afford accessibility while fitting the trail to varying terrain. An exception to the trail grade and cross slope requirements is allowed if a condition for departure exists.

Trails are to be designed with a running slope of up to:

- 1:20 (5 percent) for any distance
- 1:12 (8.33 percent) for up to 200 feet (61 meters)
- 1:10 (10 percent) for up to 30 feet (9 meters)
- 1:8 (12.5 percent) for up to 10 feet (3 meters)
- 1:7 (14 percent) into and out of drain dips for up to 5 feet (1.5 meters) where the cross slope does not exceed 1:10 (10 percent, figure 110).

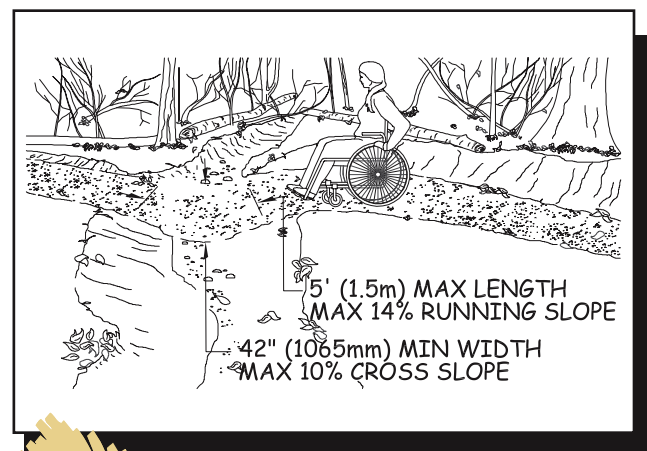

Figure 110—The requirements for accessible slopes at a drain dip.



### CONSTRUCTION TIP— *What is a slope ratio?*

Slopes are often described as a ratio of vertical distance to horizontal distance, or *rise to run* (figure 111). For instance, a slope of 1:20 means that for every foot of vertical rise, there are 20 feet of horizontal distance (or for every meter of vertical rise, there are 20 meters of horizontal distance).

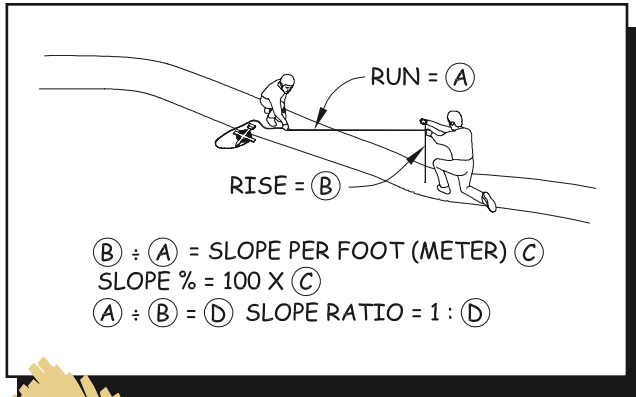

Figure 111—Determining the slope ratio.

To ensure that the trail is not designed as a series of steep segments, no more than 30 percent of the total length of the trail may exceed a grade of 1:12 (8.33 percent).

Cross slopes—the side-to-side slope of a trail tread (figure 112)—can be difficult to traverse, but provide drainage

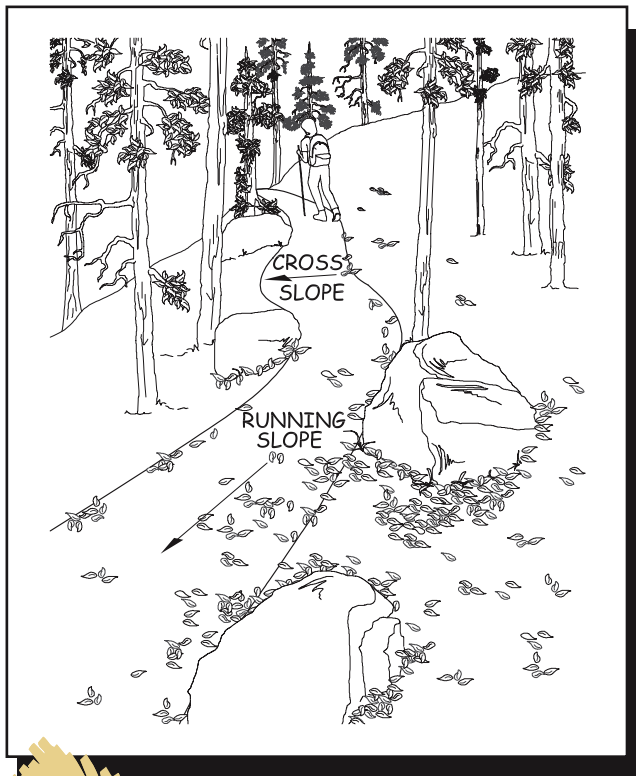

Figure 112—The running slope is measured along a trail's length; the cross slope is measured along its width.

to keep water from ponding and damaging the trail, especially on unpaved surfaces. Trails with too little cross slope tend to become streams. Water running down or ponding on them destroys the trail.

Cross slopes can't exceed 1:20 (5 percent). If a trail has at least 42 inches (1,065 millimeters) clear width at a drain dip, a cross slope of up to 1:10 (10 percent) is permitted at the bottom of the drain dip. The 42-inch (1,065-millimeter) width allows a person who uses a wheelchair to maneuver across the drain dip at an angle, minimizing the chances of tipping over (figure 110). The possibility that a wheelchair might tip over is also why the increased trail grade at a drain dip is only allowed where the cross slope is no steeper than 1:10.

## Resting Intervals on Trails

Resting intervals, relatively level areas that provide an opportunity for people to stop and catch their breath, are required any time the running slope exceeds 1:12 (8.33 percent). An exception allows a resting interval to be skipped if one can't be provided because of a condition for departure.

A resting interval is at least 60 inches (1,525 millimeters) long and at least as wide as the trail leading into it (figure 113). Depending on the design and location, the intersection of two trails may act as a resting interval (figure 114). In most cases, the slopes of a resting interval cannot exceed 1:20 (5 percent) in any direction. Where the trail grade falls between 1:20 (5 percent) and 1:12 (8.33 percent), resting intervals must be provided at least every 200 feet (61 meters). For slopes from 1:12 (8.33 percent) to 1:10 (10 percent), resting intervals must be provided at least every 30 feet (9 meters). Trail grades from 1:10 (10 percent) to 1:8 (12 percent) require resting intervals every 10 feet (3 meters).

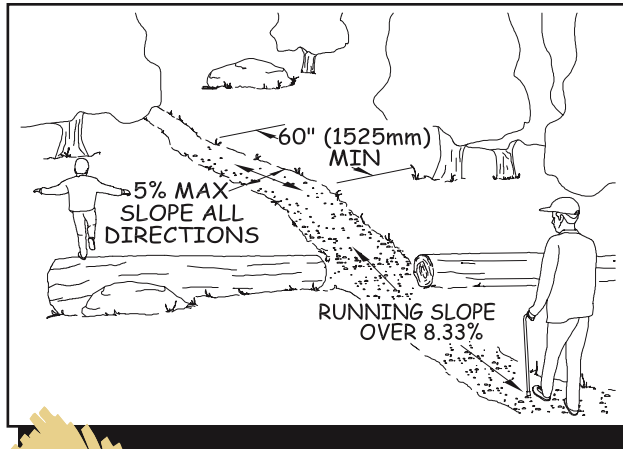

Figure 113—The requirements for resting intervals.

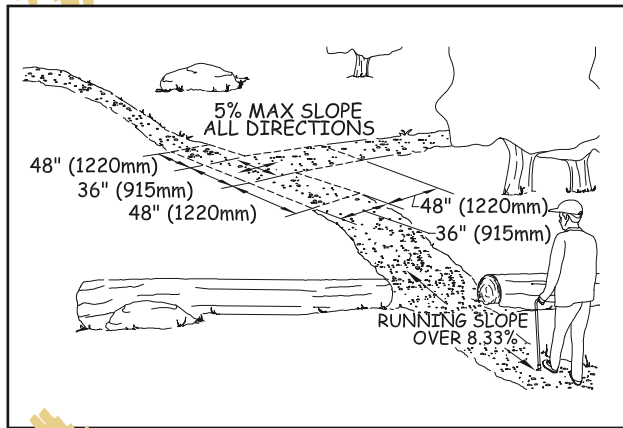

Figure 114—The requirements for a resting interval at a “T” intersection.

materials may not be suitable for every trail, which is why the exception is permitted.

Slip resistance is not required for trails because tree and shrub leaves and needles, dirt, ice, snow, and other surface debris and weather conditions are part of the natural environment that would be difficult, if not impossible, to avoid.

The FSTAG defines a firm surface as a trail surface that is not noticeably distorted or compressed by the passage of a device that simulates a person who uses a wheelchair, as explained in the design tip *What is firm and stable?* Natural soils should be evaluated during the planning process for their ability to be compacted to a firm and stable surface under normally occurring weather conditions during the primary seasons of use. The FSTAG defines a stable surface as a trail surface that is not permanently affected by normally occurring weather conditions and that is able to sustain wear and tear produced by normal use between planned maintenance cycles. The determination of firmness and stability needs to be made keeping in mind the typical conditions that occur in the vicinity of the trail being evaluated. Local trail managers know the surface and how it wears throughout the primary seasons for which the trail is managed.

## Surfaces of Trails

Trail surfaces must be firm and stable. An exception to this requirement is allowed if a condition for departure exists.

Paving with concrete or asphalt is appropriate for highly developed areas. For less developed settings, crushed gravel, fine crusher rejects, packed soil, and other natural materials may provide a firm and stable surface. Natural materials also can be combined with synthetic bonding materials that provide stability and firmness. These

## Clear Tread Width of Trails

Clear tread width means the width of the traveled surface on the ground and also above the ground between obstacles (figure 115). The clear tread of an accessible trail must be at least 36 inches (915 millimeters) wide. An exception permits the width to be reduced to 32 inches (815 millimeters) minimum if a condition for departure exists. A second exception allows an exemption from the clear tread provision if a condition for departure exists and the 32-inch (815-millimeter) width can't be achieved.

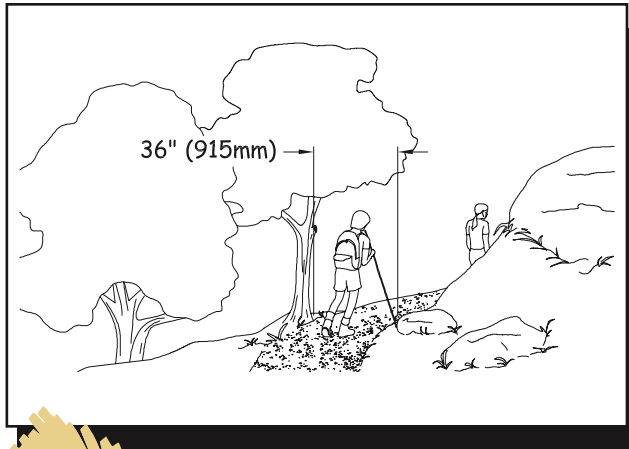

Figure 115—The requirements for clear tread width on a trail.

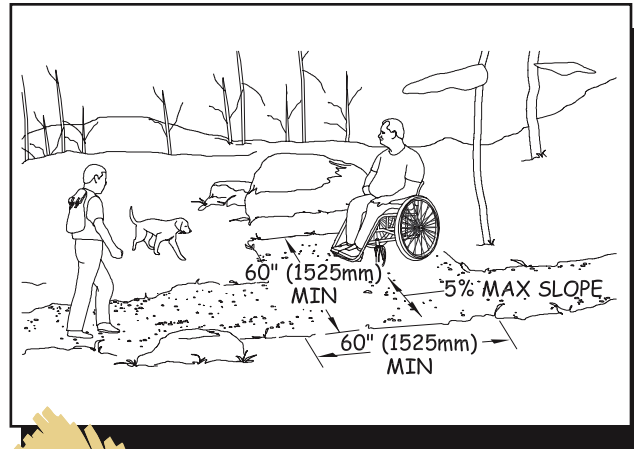

Figure 116—The requirements for passing spaces.

## Passing Spaces on Trails

86

A 60-inch (1,525-millimeter) clear tread width is required for two wheelchairs to pass comfortably and safely on a trail. However, this width is not always appropriate in all settings and for all trail classes. Where the clear tread width of a trail is less than 60 inches (815 millimeters), passing spaces are required at least every 1,000 feet (305 meters). An exemption is allowed if a passing space can't be provided because of a condition for departure.

Passing spaces must be at least 60 inches (1,525 millimeters) wide (including the trail width) by 60 inches (1,525 millimeters) long (figure 116). A "T" intersection of two trails or other walking surfaces also can be used as a passing space, provided that the arms and stem of the T-shaped space extend at least 48 inches (1,220 millimeters) beyond the intersection (figure 117). Either configuration would provide enough room for someone to move to the side and let an oncoming person pass along the trail. The cross slope of a passing space should not exceed 1:20 (5 percent).

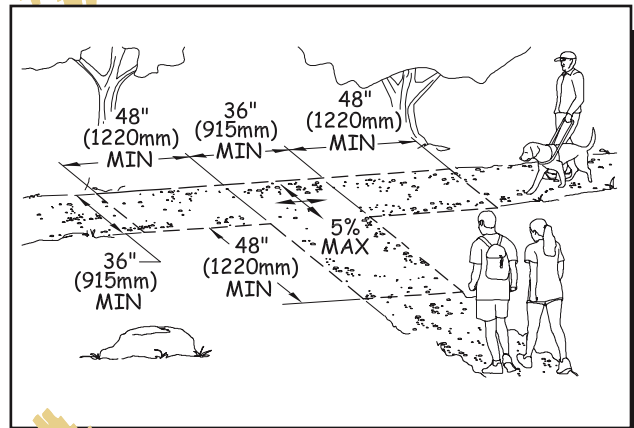

Figure 117—The requirements for passing spaces at "T" intersections.

## Tread Obstacles on Trails

A tread obstacle is anything that interrupts the evenness of the tread surface. On trails, tread obstacles often occur as a result of ruts, roots, and rocks in the tread surface. Tread obstacles generally can't be more than 2 inches (50 millimeters) high. Tread obstacles can be up to 3 inches (75 millimeters) high if the trail grade and cross slope are both 1:20 (5 percent) or less. These requirements minimize the chance that someone who uses a wheelchair might tip over when crossing a tread



obstacle. An exemption from the obstacle height requirements is allowed if compliance isn't possible because of a condition for departure.

## Protruding Objects and Trails

Protruding objects extend into the clear width area of a trail from beside or above the trail. Leaning tree trunks, rock ledges, and branches are common protruding objects. There must be at least 80 inches (2,030 millimeters) of clear headroom above trails, the same requirement as ABAAS section 307. If the vertical clearance of a trail is reduced to less than 80 inches (2,030 millimeters) because of a condition for departure, a barrier must be provided to warn people who are blind or visually impaired (figure 118). An exemption to the requirement

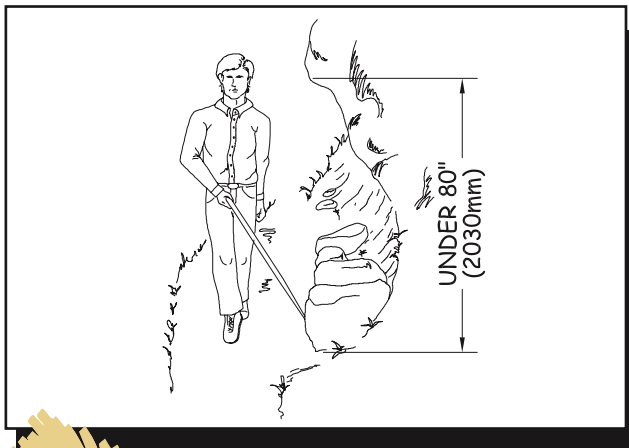

Figure 118—A warning barrier is required wherever vertical clearance is insufficient.

is allowed where a condition for departure prevents installing a barrier or providing 80 inches (2,030 millimeters) of clearance. This exception allows a trail to pass under ledges or through caves without changing the character of undeveloped areas (figure 119).

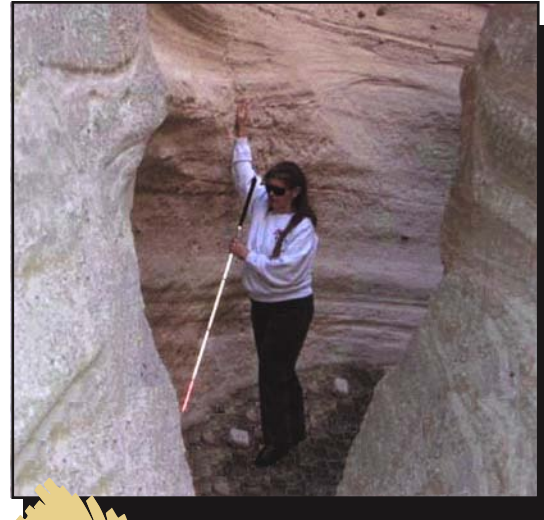

Figure 119—Entering a cave in an undeveloped area managed by the Bureau of Land Management.

## Openings in Trail Surfaces

Openings are gaps in the surface of a trail. Gaps include slots in a drainage grate and spaces between the planks on a puncheon, bridge, or boardwalk. Openings that are big enough for wheels, cane or crutch tips, or shoe heels to drop through or get stuck in are hazards that should not exist in pedestrian routes. Openings up to 1/2 inch (13 millimeters) wide are permitted in trail surfaces. Elongated openings must be placed so that the long dimension is perpendicular or diagonal to the primary direction of travel (figure 120). Elongated openings

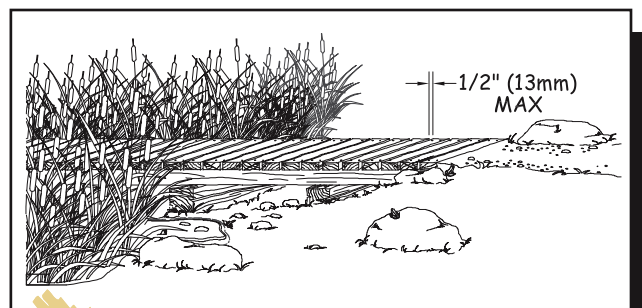

Figure 120—The requirements for openings in the trail surface that are perpendicular to the direction of travel.

less than  $\frac{1}{4}$ -inch (6.4 millimeters) wide may be used parallel to the dominant direction of travel (figure 121). This allows trail managers to place boards lengthwise along a boardwalk trail, as is often done in wetland areas.

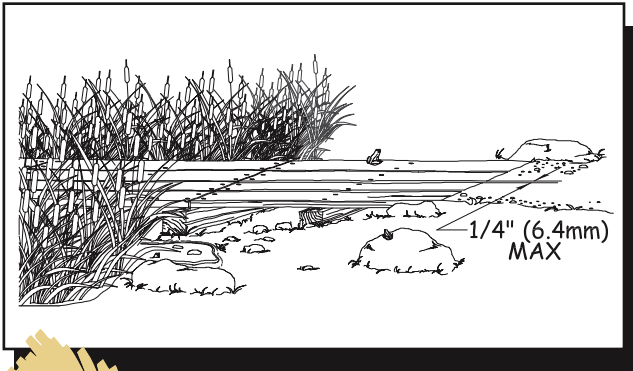

Figure 121—The requirements for openings in the trail surface that are parallel to the direction of travel.

88

If there is a condition for departure, openings less than  $\frac{3}{4}$  inch (19 millimeters) wide may be placed perpendicular or diagonal to the predominant direction of travel. This exception allows the use of boardwalk decking that needs more than  $\frac{1}{2}$ -inch- (13-millimeter-) wide spacing between the planks to permit expansion and to allow water to drain.

If one or more conditions for departure prevent the trail from meeting the requirements above, compliance with the openings provision isn't required.

## Edge Protection for Trails

Edge protection is a raised curb, wall, railing, or other projecting surface that defines the edge of a travel surface and helps keep people and assistive devices from acciden-

tally falling off the edge. Edge protection is not required for accessibility on trails. However, if edge protection is provided on a trail to improve safety or for other reasons, it should be designed appropriately for the site and must be at least 3 inches (75 millimeters) high. This is higher than the 2-inch (50-millimeter) edge protection required by the ABAAS because objects less than 3 inches (75 millimeters) high aren't easy to see or detect in the outdoors. Such objects may become a tripping hazard, particularly since natural trail surfaces tend to be irregular. In the outdoors, people with limited vision who use canes tend to search higher than they do indoors (figure 122). They use the tactile change between the trail surface and the surrounding ground surface to distinguish between the edge and the surface of the trail. Holes, slots or other openings in the edge protection may be provided for drainage or other reasons.

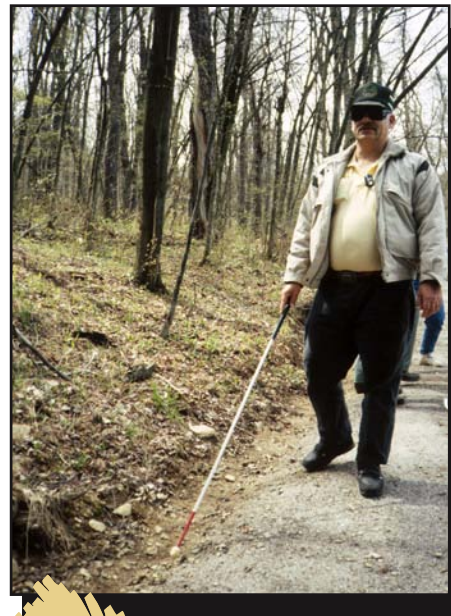

Figure 122—A hiker searches the edge of a trail.

## Signs for Trails

Local managers can decide whether to post signs on newly constructed or altered class 1, 2, or 3 hiking or pedestrian trails. If a local manager decides to post signs, they must meet the requirements explained below. Trail classes are explained in *Understanding Trail Terminology*.

Signs must be posted at the trailheads of newly constructed or altered class 4 or 5 trails and trail segments that are designed for hiker or pedestrian use, and at trailheads for trails that have been evaluated for accessibility. At a minimum, information on trailhead signs must include:

- Trail name
- Trail length
- Typical and maximum trail grade
- Typical and minimum tread width
- Typical and maximum cross slope
- Trail surface (type and firmness of surface)
- Any major height obstacle, such as boulders, in the trail tread
- A statement that posted information reflects the condition of the trail when it was constructed or assessed, including the construction or assessment date

The last requirement is because tree blowdowns, flooding, or other events can make trails designed and constructed to FSTAG standards temporarily inaccessible until maintenance crews can clear the obstruction.

Where more extensive trail information such as an aerial map of the trail and related facilities is provided, the location of specific trail features and obstacles that do not comply with the FSTAG's technical provisions should be identified and a profile of the trail grade should be included.

If materials such as maps, brochures, fee envelopes, and so on need to be obtained from or filled out at a sign or kiosk, the sign or kiosk must be designed to meet the standard reach ranges of a person in a wheelchair in accordance with ABAAS section 308 as explained in *Reach Ranges and Operability Requirements*. In addition, 30- by 48-inch (760- by 1,220-millimeter) clear floor or ground spaces must be provided to allow for forward or side approach.



# Constructed Features Associated With Trails

In the FSTAG, the term *associated constructed features* refers to tent pads and platforms, pit toilets, viewing areas, benches, warming huts, and similar structures for trail users. To comply with the Architectural Barriers Act of 1968 and Section 504 of the Rehabilitation Act of 1973 (Section 504), associated constructed features provided along trails—even trails that are not accessible—must be designed to comply with the applicable provisions in the FSORAG.

The path of travel between associated constructed features, as well as the path connecting them to a trail, must comply with the FSTAG. These paths are not ORARs and are not required to meet the technical provisions for an ORAR.

trail at North Doublehead in New Hampshire. The toilet was constructed in 1972, after the 1968 passage of the ABA. The Forest Service replaced the toilet with an accessible model.

It's really in the best interests of all organizations to ensure that all facilities—regardless of where they are located—are appropriate to the setting and are accessible. When accessibility is integrated into the design from the beginning, there's not much difference in cost. If the design of a facility that's already under construction must be changed to provide for accessibility, or if an inaccessible facility has to be replaced with an accessible facility at a later date, costs will be substantial.

90

## DESIGN TIP—

***If the trail isn't accessible, why does the warming hut have to be accessible?***

This issue was clarified for Federal agencies when a complaint was filed with the U.S. Access Board against the National Park Service for installing an inaccessible toilet at 10,000 feet (3,048 meters) on Mt. Rainer. The petitioner was a paraplegic who was climbing the mountain with a sit-ski and ropes. He was not able to use the toilet that the rest of his party could use, because it wasn't accessible. The Access Board found that the Park Service was not in compliance with the 1968 Architectural Barriers Act that requires all new construction funded by Federal Executive agencies to be accessible. The Park Service settled the case by replacing the toilet with an accessible model.

The Forest Service was cited by the Access Board after a complaint was filed about a toilet serving the

Associated constructed features must be designed appropriately for the setting and in compliance with the applicable provisions in the FSORAG to ensure that the facility can be used for its primary purpose by all hikers, including hikers with disabilities. For example, a trail hut or lean-to with three walls may be provided along a trail. If its floor is above the ground, at least one section of the floor on the open side of the hut must be 17 to 19 inches (430 to 485 millimeters) above the ground to facilitate transfer onto the floor from a wheelchair, as explained in *Warming Huts*.

Requirements for all recreation facilities, including those that are commonly associated with trails, are contained in the FSORAG and explained in the section titled Applying the Forest Service Outdoor Recreation Accessibility Guidelines. The requirements for tent pads are explained in *Camp Unit Tent Pads and Tent Platforms*. The requirements for pit toilets are explained in *Pit Toilets in General Forest Areas*. Constructed features associated with trails must meet the requirements for those features provided in GFAs.

*Continued* ↗





## Overview of the FSTAG Implementation Process

Now that you have learned about the extent of application, general exceptions, and the technical provisions, you may be wondering how the whole process ties together. A process overview chart that graphically summarizes the FSTAG steps and sequencing is included below. It guides the trail designer through a series of questions to determine if the FSTAG would apply to the trail being designed. Following this process also enables trail designers to verify that opportunities to provide the highest level of accessibility have been evaluated and that the character, trail class, and experience of the setting have not been changed. You may want to look at a copy of the chart while reading the following explanation of its use.

### Step 1—Determine the applicability of the FSTAG

Once a decision has been made to design or alter a trail, three questions must be asked:

- 1—Is the designed use “hiker/pedestrian”?  
If yes,
- 2—Does the work meet the definitions for new construction or alteration that are explained in *Understanding Trail Terminology*?  
If yes,
- 3—Does the proposed trail connect to a trailhead or accessible trail? *Trailhead* is defined in *Understanding Trail Terminology*.

If the answer to any of those questions is *no*, the FSTAG does not apply and no further analysis is required. The finding and reasons that the FSTAG does not apply should be briefly documented and put in the project file. Even so, it is always desirable to incorporate accessibility where opportunities exist.

If the answer to all three questions is *yes*, the designer moves to step 2.



### DESIGN TIP—

#### ***No substitute for on-the-ground layout***

In order to work through steps 2, 3 and 4 of the overview process, trail designers should have a proposed trail alignment identified on the ground. The review and analysis required in these steps must be based on actual field conditions, rather than relying only on topographic maps.

### Step 2—Identify the presence of limiting factors

This step addresses General Exception 1 and the four limiting factors that are explained in *Using the General Exceptions in the FSTAG*. The sequence for identifying the limiting factors may vary and does not need to be done in the order illustrated in the process overview chart.

Let’s work our way through the process overview chart by asking four questions, each related to one of the limiting factors. The first question will be explained in detail to serve as an example for the other three.

#### **“Does the combined trail grade and cross slope exceed 20 percent for a continuous distance of 40 feet (12 meters) or more?”**

If not, the FSTAG may still apply, so you should consider the next limiting factor. A *continuous distance* means a sustained grade without rest areas or more moderate grades or grade breaks. If the alignment can be relocated to get a more moderate grade, this limiting factor doesn’t apply.

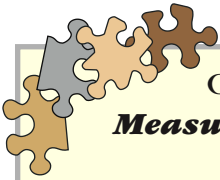

**CONSTRUCTION TIP—  
Measuring grade**

Grade can be measured in a number of ways. An informal survey can be done between obvious trail grade breaks with a hand level, survey rod, and measuring chain (figure 123). A digital level can also be used (figure 124). A detailed universal trail assessment process that uses a clinometer and digital inclinometer to measure grade and cross slope has been developed by Beneficial Designs. More information about this process and the instruments needed to perform the assessment are available at: <http://www.beneficialdesigns.com/trails/utap.html#overview%20background>.

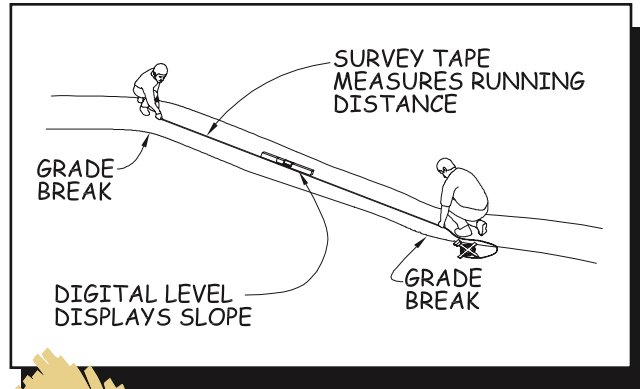

Figure 124—Surveying trail grade with a digital level.

still apply, so you should proceed to the next limiting factor.

If a condition for departure does exist, document the length of trail that exceeds those grades, the location of the area, and your data source (field survey, clinometer, etc.). The FSTAG requirements don't apply beyond the section with excessive grade.

Next, determine whether the extreme grade and cross slope are more than 500 feet (152 meters) from either end of the trail. If so, FSTAG requirements apply between the end of the trail and this limiting factor. If not, determine whether there is a prominent feature between the end of the trail and this limiting factor. If there is a prominent feature, FSTAG requirements apply from the end of the trail to the prominent feature. If there is no prominent feature, the FSTAG does not apply to this trail at all and no further review or analysis is required. This determination and the applicable condition for departure should be documented for the project file.

Work your way through the other three limiting factors the same way.

**“Is the surface unfirm or unstable for 45 feet (14 meters) or more?”**

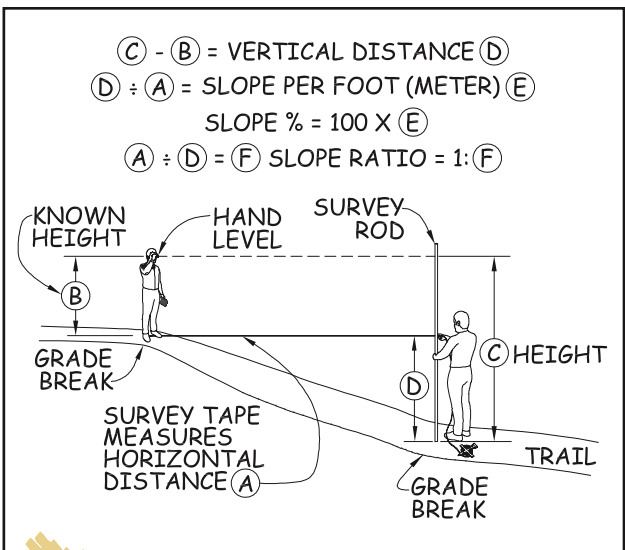

Figure 123—Surveying trail grade with a hand level.

If the grade and cross slope are exceeded, you would need to determine whether a condition for departure exists that permits a deviation from the required grade. If there is no condition for departure, the FSTAG may



DESIGN TIP—  
***What is firm and stable?***

In the late 1990s, the Access Board funded an Accessible Exterior Surfaces research project conducted by Beneficial Designs of Minden, NV. Results of the study are available on the Access Board's Web site at: <http://www.access-board.gov/research/Exterior%20Surfaces/exteriorsarticle.htm>. Figure 31 shows the rotational penetrometer tool that can be used to evaluate surfaces. For further information, consult Beneficial Designs' Web site at: <http://www.beneficialdesigns.com/>. One of the results of the project was development of a scientific method for determining firm and stable exterior surfaces.

Figure 125 shows the rotational penetrometer tool that can be used to evaluate surfaces. For further information, consult Beneficial Designs' Web site at: <http://www.beneficialdesigns.com/>.

What sort of surface is firm and stable? In general, if the answer to both of the following questions is *yes*, the surface is probably firm and stable.

- Could a person ride a narrow-tired bicycle across the surface easily without making ruts? (The bicycle tires are similar to large rear wheels of a wheelchair.)
- Could a folding stroller with small, narrow plastic wheels containing a 3-year-old be pushed easily across the surface without making ruts? (The stroller's wheels are similar to the front wheels of a wheelchair.)

While this method for determining firmness and stability isn't scientifically accurate, it has proven to be effective.



Figure 125—Using the rotational penetrometer to determine whether a surface is firm and stable.

**“Is the trail width 18 inches (455 millimeters) or less for a distance of at least 20 feet (6 meters)?”**



DESIGN TIP—  
***Determining when trail width is a limiting factor***

Measuring the existing trail width is easy—just use a measuring tape to get the side-to-side distance of the narrowest stretch of trail. Figuring out if you're stuck with that width may be a little more difficult. The trail may be less than 18 inches (455 millimeters) wide, but if you can widen it in its current location or move the trail alignment to an area where it can be wider, the limiting factor doesn't apply.

**“Is there a trail obstacle at least 30 inches (760 millimeters) high?”**

If you find a limiting factor where a condition for departure applies, there’s no reason to evaluate the trail beyond that point for successive limiting factors. Just look at the section of trail between the limiting factor or prominent feature and the trail terminus. If there are no limiting factors that would prevent compliance with the FSTAG, proceed to step 3.

**Step 3—Apply the Technical Provisions.**

This step involves looking at FSTAG sections 7.3.1 through 7.3.8, which are the provisions for trail grade, cross slope, resting interval, surface, clear tread width, passing space, tread obstacles, protruding objects, and openings. The provisions for edge protection and signs aren’t included because they don’t affect the accessibility of the trail to the extent the other provisions do.

94

This summary and the process overview chart do not contain everything you need to know about trail requirements. Designers must refer to the FSTAG for detailed instructions, definitions, conditions for departure, technical provisions 7.0 through 7.3.10, and exceptions.

A series of questions with yes or no answers is asked for each of the provisions listed above, similar to step 2. Let’s take trail grade as an example.

First, look at the existing conditions on the ground and determine whether the trail alignment complies with the required grades (1:20 for any distance, 1:12 for up to 200 feet [61 meters], 1:10 for up to 30 feet [9 meters], and so forth). If not, is there a condition for departure that

would prevent adjusting the trail alignment or making other changes to achieve compliance? If a condition for departure exists, measure and record the length of the deviation and proceed to the next provision. If the trail alignment complies with the required grades or there is no condition for departure, compliance with the provision for trail grade is required.

Each technical provision is addressed in a similar manner. A determination is made for every provision: either compliance is required, or deviations are permitted. Be sure to measure and record the length of each deviation from a particular provision. Once you have worked through the provisions, proceed to the last step.



If at any point during step 3 you find that the recorded length of deviations from the provisions adds up to 15 percent or more of the total trail length, proceed directly to step 4.



**Step 4—Calculate Cumulative Deviation Percentage.**

This is the final step in determining how much of the trail must comply with the FSTAG as addressed by general exception 2.

Tally up the measurements of permitted deviations from step 3. If they occur on less than 15 percent of the total trail length, the FSTAG technical provisions apply to the entire trail.

However, if the length of permitted deviations is 15 percent or more of the total trail length, the FSTAG applies to only part of the trail, or may not apply at all.

If the first deviation occurs more than 500 feet (152 meters) from one end of the trail, apply the FSTAG from that end of the trail to the first deviation.

If the first deviation occurs less than 500 feet (152 meters) from one end of the trail and a prominent feature is between the end of the trail and the deviation, the FSTAG applies from that end of the trail to the prominent feature.

If the first deviation occurs less than 500 feet (152 meters) from one end of the trail and no prominent feature is between the end of the trail and the deviation, the FSTAG doesn't apply to the trail.



**DESIGN TIP—  
Applying the process**

Figure 126 helps illustrate how to apply the process by calculating cumulative deviations and considering a prominent feature. The drawing shows that:

- Deviations occur on more than 15 percent of the trail because 15 percent of 950 feet = 142.5 feet (15 percent of 290 meters = 43.5 meters), but the deviations total 216 feet (66 meters).
- The first point of deviation occurs 400 feet (122 meters) from the trailhead.
- The vista is only 250 feet (76 meters) from the trailhead.

The trail must comply with the guidelines from the trailhead to the vista. Beyond the vista, the trail does not have to comply with the guidelines.

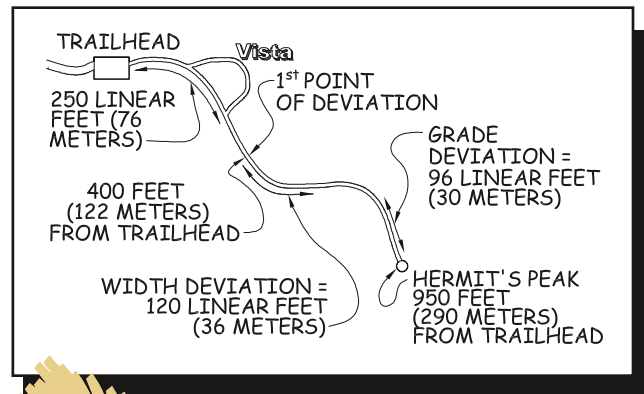

Figure 126—This trail schematic illustrates how to determine where the trail must comply with the FSTAG.

That's all there is to it!

## Trail Layout Notes



# Overview Chart of the FSTAG Implementation Process

The FSTAG must be applied before initiating new construction or altering any National Forest System trail with a designed use of hiker/pedestrian. Table 4 distills the implementation process into a flow chart that provides easy reference as you work through the process. Before applying the FSTAG, you'll need to:

- Analyze existing conditions, including potential opportunities and constraints (National Environmental Policy Act analysis).
- Identify and verify the desired trail class for the trail or trail segment.
- Identify and verify the designed use of the trail or trail segment.

Table 4—Overview of the FSTAG implementation process: key steps and sequence.

<b>Step 1: Determine applicability of the FSTAG.</b>	Designed use <sup>1</sup> = hiker/pedestrian? <b>YES</b> ↓	<b>NO →</b>	FSTAG does not apply.
	New construction or alteration? <b>YES</b> ↓	<b>NO →</b>	FSTAG does not apply.
	Trail connects to a trailhead or accessible trail? <b>YES</b> ↓	<b>NO →</b>	FSTAG does not apply.
	<b>Proceed to step 2 (Identify presence of limiting factors)</b>		



*Because of the large format of table 4, please turn the page. ↪*

Table 4—(Continued.)

<p><b>Step 2: Identify presence of limiting factors</b></p> <p>General Exception 1 (7.2.1)</p> <p>Note: Sequence for identifying limiting factors may vary and does not need to occur in the order illustrated here.</p>	<p><b>TRAIL GRADE</b> exceeds 20% for 40 feet (12 meters) or more?</p>	<p><b>NO</b> →</p>		<p><b>NO</b> →</p>	
		<p><b>YES</b> → Document length of trail that exceeds 20% and data source.</p>	<p>Does condition for departure exist?</p>	<p><b>YES</b> →</p>	
	<p><b>SURFACE</b> <i>not</i> firm and stable for 45 feet (14 meters) or more?</p>	<p><b>NO</b> (The surface <i>is</i> firm and stable.) →</p>		<p><b>NO</b> →</p>	
		<p><b>YES</b> → (The surface is not firm and stable.) Document surface firm- ness and data source.</p>	<p>Does condition for departure exist?</p>	<p><b>YES</b> →</p>	
	<p><b>MINIMUM TRAIL WIDTH</b> less than 18 inches (457 millimeters) for 20 feet (6 meters) or more?</p>	<p><b>NO</b> →</p>		<p><b>NO</b> →</p>	
		<p><b>YES</b> → Document minimum trail width and data source.</p>	<p>Does condition for departure exist?</p>	<p><b>YES</b> →</p>	
	<p><b>TRAIL OBSTACLE</b> 30 inches (762 millimeters) or higher across width of trail?</p>	<p><b>NO</b> →</p>		<p><b>NO</b> →</p>	
		<p><b>YES</b> → Document obstacle type, dimen- sions, and data source.</p>	<p>Does condition for departure exist?</p>	<p><b>YES</b> →</p>	



					FSTAG may still apply. Proceed to limiting factor for <b>surface</b> .
Is limiting factor more than 500 feet (152 meters) from trail terminus?	<b>YES →</b>				FSTAG applies between terminus and this limiting factor or prominent feature. <b>Proceed to Step 3</b> (Apply Technical Provisions).
	<b>NO →</b>	Prominent feature present?	<b>YES →</b>		FSTAG applies between terminus and this limiting factor or prominent feature. <b>Proceed to Step 3</b> (Apply Technical Provisions).
				<b>NO →</b>	FSTAG does not apply. Document applicable condition for departure.
					FSTAG may still apply. Proceed to limiting factor for <b>minimum trail width</b> .
Is limiting factor more than 500 feet (152 meters) from trail terminus?	<b>YES →</b>				FSTAG applies between terminus and this limiting factor or prominent feature. <b>Proceed to Step 3</b> (Apply Technical Provisions).
	<b>NO →</b>	Prominent feature present?	<b>YES →</b>		FSTAG applies between terminus and this limiting factor or prominent feature. <b>Proceed to Step 3</b> (Apply Technical Provisions).
				<b>NO →</b>	FSTAG does not apply. Document applicable condition for departure.
					FSTAG may still apply. Proceed to limiting factor for <b>trail obstacle</b> .
Is limiting factor more than 500 feet (152 meters) from trail terminus?	<b>YES →</b>				FSTAG applies between terminus and this limiting factor or prominent feature. <b>Proceed to Step 3</b> (Apply Technical Provisions).
	<b>NO →</b>	Prominent feature present?	<b>YES →</b>		FSTAG applies between terminus and this limiting factor or prominent feature. <b>Proceed to Step 3</b> (Apply Technical Provisions).
				<b>NO →</b>	FSTAG does not apply. Document applicable conditions for departure.
					FSTAG may still apply. <b>Proceed to Step 3</b> (Apply Technical Provisions).
Is limiting factor more than 500 feet (152 meters) from trail terminus?	<b>YES →</b>			<b>YES →</b>	FSTAG applies between terminus and this limiting factor or prominent feature. <b>Proceed to Step 3</b> (Apply Technical Provisions).
	<b>NO →</b>	Prominent feature present?	<b>YES →</b>		FSTAG applies between terminus and this limiting factor or prominent feature. <b>Proceed to Step 3</b> (Apply Technical Provisions).
				<b>NO →</b>	FSTAG does not apply. Document applicable conditions for departure.

Table 4—(Continued.)

<p><b>Step 3: Apply technical provisions</b></p> <p>Technical Provisions (7.3.1 to 7.3.8)</p>	TRAIL GRADE complies with 7.3.1.1?	YES →					
		NO →	Does condition for departure exist?	YES	Deviation permitted. Measure and record length of deviation.	→	
					NO	Deviation not permitted.	→
	TRAIL CROSS SLOPE complies with 7.3.1.2?	YES →					
		NO →	Does condition for departure exist?	YES	Deviation permitted. <sup>2</sup> Measure and record length of deviation.	→	
					NO	Deviation not permitted.	→
	RESTING INTERVAL complies with 7.3.2?	YES →					
		NO →	Does condition for departure exist?	YES	Deviation permitted. <sup>2</sup> Measure and record length of deviation.	→	
					NO	Deviation not permitted.	→
	SURFACE complies with 7.3.3?	YES →					
		NO →	Does condition for departure exist?	YES	Deviation permitted. <sup>2</sup> Measure and record length of deviation.	→	
					NO	Deviation not permitted.	→
	CLEAR TREAD WIDTH complies with 7.3.4?	YES →					
		NO →	Does condition for departure exist?	YES	Deviation permitted. <sup>2</sup> Measure and record length of deviation.	→	
				NO	Deviation not permitted.	→	
PASSING SPACE complies with 7.3.5?	YES →						
	NO →	Does condition for departure exist?	YES	Deviation permitted. <sup>2</sup> Measure and record length of deviation.	→		
				NO	Deviation not permitted.	→	

	Comply with trail grade technical provision 7.3.1.1.	
		<b>Proceed to Step 4:</b> calculate cumulative deviation percentage.
	Comply with trail grade technical provision 7.3.1.1.	
	Comply with trail grade technical provision 7.3.1.2.	
		<b>Proceed to Step 4:</b> calculate cumulative deviation percentage.
	Comply with trail grade technical provision 7.3.1.2.	
	Comply with trail grade technical provision 7.3.2.	
		<b>Proceed to Step 4:</b> calculate cumulative deviation percentage.
	Comply with trail grade technical provision 7.3.2.	
	Comply with trail grade technical provision 7.3.3.	
		<b>Proceed to Step 4:</b> calculate cumulative deviation percentage.
	Comply with trail grade technical provision 7.3.4.	
	Comply with trail grade technical provision 7.3.4.	
		<b>Proceed to Step 4:</b> calculate cumulative deviation percentage.
	Comply with trail grade technical provision 7.3.4.	
	Comply with trail grade technical provision 7.3.5.	
		<b>Proceed to Step 4:</b> calculate cumulative deviation percentage.
	Comply with trail grade technical provision 7.3.5.	
		<i>Step 3 continued</i> ↗

Table 4—(Continued.)

<b>Step 3: Apply technical provisions</b>  Technical Provisions (7.3.1 to 7.3.8)	TREAD OBSTACLES comply with 7.3.6?	<b>YES →</b>					
		<b>NO →</b>	Does condition for departure exist?	<b>YES</b>	Deviation permitted. <sup>2</sup> Measure and record length of deviation.	→	
	PROTRUDING OBJECTS comply with 7.3.7?	<b>YES</b>					
		<b>NO →</b>	Does condition for departure exist?	<b>YES</b>	Deviation permitted. <sup>2</sup> Measure and record length of deviation.	→	
	OPENINGS comply with 7.3.8?	<b>YES →</b>					
		<b>NO →</b>	Does condition for departure exist?	<b>YES</b>	Deviation permitted. <sup>2</sup> Measure and record length of deviation.	→	
			<b>NO</b>	Deviation not permitted.	→		

<b>Step 4: Calculate cumulative deviation percentage</b>  General Exception 2 (7.1.2.2)	CUMULATIVE DEVIATION PERCENTAGE Do permitted deviations occur on less than 15% of total trail length?	<b>YES →</b>				Apply FSTAG technical provisions to entire trail. <sup>3</sup>
		<b>NO →</b>	Is first deviation more than 152 meters (500 feet) from trail terminus?	<b>YES →</b>		Apply FSTAG technical provisions to segment of trail between terminus and first point of deviation. <sup>3</sup>
				<b>NO →</b>	Does prominent feature exist?	<b>YES →</b>
						<b>NO →</b>

If you have questions about applying any of the above information, please contact your region's recreation accessibility coordinator. Current contact information

is available on the Forest Service's internal computer network at: <http://fsweb.mtdc.wo.fs.fed.us/toolbox/acc/documents/coord.htm>.



	Comply with trail grade technical provision 7.3.6.	
		<b>Proceed to Step 4:</b> calculate cumulative deviation percentage.
	Comply with trail grade technical provision 7.3.6.	
	Comply with trail grade technical provision 7.3.7.	
		<b>Proceed to Step 4:</b> calculate cumulative deviation percentage.
	Comply with trail grade technical provision 7.3.7.	
	Comply with trail grade technical provision 7.3.8.	
		<b>Proceed to Step 4:</b> calculate cumulative deviation percentage.
	Comply with trail grade technical provision 7.3.8.	

<sup>1</sup>Excerpt from *Forest Service Trail Fundamentals* ([www.fs.fed.us/r3/measures/Inventory/Trails.htm](http://www.fs.fed.us/r3/measures/Inventory/Trails.htm)). Definition of designed use: “The intended use that *controls* the desired geometric design of the trail, and determines the subsequent maintenance parameters for the trail.... Of the actively Managed Uses that the trail is developed and managed for, the Designed Use is the *single design driver* that determines the technical specifications for the trail.”

Excerpt from Access Board *Recommendations for Accessibility Guidelines: Outdoor Developed Areas, Final Report* (page 11): “*The accessibility guidelines for trails apply to those which are designed and constructed for pedestrian use.* These guidelines are not applicable to trails primarily designed and constructed for recreational use by equestrians, mountain bicyclists, snowmobile users, or off-highway vehicle users, even if pedestrians may occasionally use the same trails. People use these categories of trails by means of transportation other than foot travel or personal mobility device. Design and constructed requirements for equestrians, mountain bikes, OHVs, and snowmobiles are based on the specific requirements for the intended mode of transportation. For the safety of trail users, pedestrian use may not always be permitted on these trails in order to minimize conflicts between motorized and non-motorized recreation. These trails do not preclude use by a person with a disability since it is planned that all trail users would be using the one or more alternative means of transportation for which the trail is designed and constructed. The design and construction of pedestrian trails without consideration of these proposed guidelines, by contrast, could present barriers to some trail users because the intended use is by foot or personal mobility device. For these reasons, the committee intentionally limited the application of the proposed guidelines to pedestrian use trails.”

It should be noted that the definition used in these proposed guidelines is not the only definition used by trail designers and manager. Rather, it was developed to specifically define the scope of these guidelines.”

<sup>2</sup>If at any point during Step 3 the occurrence of one or more conditions of departure result in permitted deviations from technical provisions on more than 15 percent of the trail length, proceed to Step 4.

<sup>3</sup>Refer to the FSTAG for detailed instructions, definitions, and technical provisions 7.0 through 7.3.

# A cronyms

ABA—Architectural Barriers Act	GFA—General Forest Area
ABAAS—Architectural Barriers Act Accessibility Standards	GSA—U.S. General Services Administration
Access Board—Architectural and Transportation Barriers Compliance Board	HUD—U.S. Department of Housing and Urban Development
ADA—Americans with Disabilities Act	IBC—International Building Code
ADAAG—Americans with Disabilities Act Accessibility Guidelines	ISA—International Symbol of Accessibility
ANSI—American National Standards Institute	ITDS—Interagency Trail Data Standards
ATV—All-terrain vehicle	MUTCD—Manual of Uniform Traffic Control Devices
BEIG—Built Environment Image Guide	OHV—Off-highway vehicle
CFR—Code of Federal Regulations	ORAR—Outdoor Recreation Access Route
DOD—U.S. Department of Defense	RHRIBS—Recreation & Heritage Resources Integrated Business Systems
FHWA—U.S. Department of Transportation Federal Highway Administration	ROS—Recreation Opportunity Spectrum
FSORAG—Forest Service Outdoor Recreation Accessibility Guidelines	RRAC—Regional Recreation Accessibility Coordinator
FSTAG—Forest Service Trail Accessibility Guidelines	RV—Recreational Vehicle
	TTY—Teletypewriter
	UFAS—Uniform Federal Accessibility Standards
	USDA—U.S. Department of Agriculture
	USPS— U.S. Postal Service

# D

## Definitions

- Accessibility Evaluation Survey**—Comparing each portion of a structure to the accessibility standards and recording compliance and deficiencies.
- Accessible**—Capable of being reached; often used to describe facilities or amenities that can be used by people with disabilities.
- Accessible Facilities**—Facilities that comply with the accessibility guidelines.
- Alteration**—A change in the original purpose, intent, or function for which the trail, recreation site, or facility was designed.
- Conditions for Departure (from the accessibility guidelines)**—Circumstances found in natural environments that may make it difficult to comply with the accessibility guidelines.
- Construction**—Building a new trail, recreation site, or facility where there was none before.
- Disability**—A medically definable condition that causes a limitation in one or more major life activities such as walking, seeing, hearing, speaking, breathing, thinking, and so forth.
- Feasible**—Can be accomplished with a reasonable amount of effort or with customary practices.
- Firm and Stable Surface**—A surface that is not noticeably distorted or compressed and that doesn't shift during the passage of a device that simulates a person using a wheelchair.
- Grab Bars**—Provide stability and allow someone to use his or her arms to assist in moving over short distances.
- Guardrails**—Protect people from dropoffs.
- Handrails**—Provide a steadying grip when going up or down stairs or inclines.
- Interagency Trail Data Standards**—National Trail Data Standards agreed to by the U.S. Department of Agriculture Forest Service and the U.S. Department of the Interior Bureau of Land Management, Fish and Wildlife Service, National Park Service, and Bureau of Reclamation.
- Limiting Factor**—An extreme, uncorrectable environmental barrier that makes the trail beyond the barrier unreachable for many people with mobility limitations.
- Maintenance**—Routine or periodic repair of existing trails, recreation sites, or facilities. Maintenance does not change the original purpose, intent, or function for which the facility was designed.
- Pit Toilet**—A simple toilet provided in a general forest area with waste disposed directly into the ground or that relies on moldering or composting.
- Program Accessibility**—Providing all people, including people with disabilities, the opportunity to participate in a program—an activity in which someone may participate or the reason someone visits an area.
- Reconstruction**—This term is not used in Federal accessibility guidelines or the FSORAG and FSTAG, even though it is used frequently by folks who work in recreation and trails. For the purposes of the FSORAG and FSTAG, actions are categorized as construction, alteration, or maintenance.
- Scoping**—The term used for the process of figuring out when, how much, and where the guidelines apply.
- Setting**—The term used to describe the natural surroundings of a trail or recreation area.
- Slope Ratio**—A ratio of vertical distance to horizontal distance, or *rise* to *run*.
- Technical Provisions**—Specific physical characteristics that are required to make the built environment accessible, as identified in the accessibility guidelines.
- Trail Classes**—Broadly characterize and group trails by desired management characteristics and level of development, while taking into account user preferences, the recreation setting, protection of sensitive resources, and other factors. See the Interagency Trail Data Standards.
- Trail Designed Use**—The intended use that controls the geometric design of a trail and determines the level to which it should be maintained. See the Interagency Trail Data Standards.
- Trail Managed Use**—Any mode of travel that is actively managed and appropriate for a specific trail or area. See the Interagency Trail Data Standards.

**Trailhead**—A site designed and developed by the Forest Service or other government agency, a trail association, trail maintaining club, or other cooperators to provide a staging area for trail use.

**Transition Plan**—Identifies the changes needed to make a facility accessible and the timeline for completing the changes.

**Universal Design**—Programs and facilities designed to be usable by all people, to the greatest extent possible, without separate or segregated access for people with disabilities.

**Warming Hut**—A temporary space or partially enclosed space used briefly for protection from the weather.





## Source Documents

- Forest Service Outdoor Recreation Accessibility Guidelines: <http://www.fs.fed.us/recreation/programs/accessibility/FSORAG.doc>
- Forest Service Trails Accessibility Guidelines: <http://www.fs.fed.us/recreation/programs/accessibility/FSTAG.doc>

## Links

- **7 CFR 15** is the 1994 USDA implementation guideline for Section 504 that prescribes the requirements for ensuring access to programs.
  - Subpart 15b (covers programs operating with Federal agency funding under special use permits or other agreements): [http://www.access.gpo.gov/nara/cfr/waisidx\\_03/7cfr15b\\_03.html](http://www.access.gpo.gov/nara/cfr/waisidx_03/7cfr15b_03.html)
  - Subpart 15e (covers programs conducted by the Forest Service): [http://www.access.gpo.gov/nara/cfr/waisidx\\_03/7cfr15e\\_03.html](http://www.access.gpo.gov/nara/cfr/waisidx_03/7cfr15e_03.html)
  - Section 150d (transition plan development and contents): [http://www.access.gpo.gov/nara/cfr/waisidx\\_03/7cfr15d\\_03.html](http://www.access.gpo.gov/nara/cfr/waisidx_03/7cfr15d_03.html)
- Access Board—<http://www.access-board.gov/>
- Accessibility Guidebook for Outfitters/Guides Operating on Public Lands—<http://www.fs.fed.us/recreation/programs/accessibility/>
- Accessibility Guidebook for Ski Areas Operating on Public Lands—<http://www.fs.fed.us/recreation/programs/accessibility/>
- Accessible Exterior Surfaces Technical Article—<http://www.access-board.gov/research/Exterior%20Surfaces/exteriorsarticle.htm>

- Accessible Handpump—<http://www.fs.fed.us/t-d/programs/eng/handpump.htm>
- ADAAG Accessibility Checklist for Buildings and Facilities—<http://www.access-board.gov/adaag/checklist/a16.html>
- American Trails—<http://www.americantrails.org>
- Americans With Disabilities Act (ADA)—<http://www.access-board.gov/about/laws/ADA.htm>
- Americans With Disabilities Act/Architectural Barriers Act Accessibility Guidelines—<http://www.access-board.gov/ada-aba/>
- Architectural Barriers Act (ABA)—<http://www.access-board.gov/about/laws/ABA.htm>
- Architectural Barriers Act Accessibility Standards (ABAAS)—<http://www.access-board.gov/ada-aba/>
- Backcountry Sanitation Manual—<http://www.appalachiantrail.org/protect/steward/sanman.html>
- Beneficial Designs—<http://www.beneficialdesigns.com/>
- Built Environment Image Guide (BEIG)—<http://www.fs.fed.us/recreation/programs/beig/>
- Designing Sidewalks and Trails for Access
  - Part 1, Review of Existing Guidelines and Practices—<http://www.fhwa.dot.gov/environment/sidewalks/index.htm>
  - Part 2, Best Practices Design Guide—<http://www.fhwa.dot.gov/environment/sidewalk2/index.htm>
- Facilities Toolbox—<http://fsweb.mtdc.wo.fs.fed.us/toolbox/>

- Federal Highway Administration/USDA Forest Service recreational trail publications and videos—<http://www.fhwa.dot.gov/environment/fspubs/index.htm>  
—Paper copies—<http://www.fhwa.dot.gov/environment/rectrails/trailpub.htm>
- Forest Service recreation opportunities—<http://www.fs.fed.us/recreation/>
- Forest Service National Trail Specifications—<http://www.fs.fed.us/database/acad/dev/trails/trails.htm>
- Forest Service Outdoor Recreation Accessibility Guidelines (FSORAG)—<http://www.fs.fed.us/recreation/programs/accessibility/>
- Forest Service Trail Accessibility Guidelines (FSTAG)—<http://www.fs.fed.us/recreation/programs/accessibility/>
- Forest Service Trail Design Parameters—[http://www.fs.fed.us/r3/measures/Inventory/trails%20files/National\\_Design\\_Parameters\\_1\\_31\\_2005.doc](http://www.fs.fed.us/r3/measures/Inventory/trails%20files/National_Design_Parameters_1_31_2005.doc)
- Infra—<http://infra.wo.fs.fed.us/infra/>
- Interagency Trail Data Standards—<http://www.nps.gov/gis/trails/> and [http://www.fs.fed.us/r3/measures/Inventory/trails%20files/Trail\\_Class\\_Matrix\\_1\\_31\\_2005.doc](http://www.fs.fed.us/r3/measures/Inventory/trails%20files/Trail_Class_Matrix_1_31_2005.doc) (Also in the FSTAG: <http://www.fs.fed.us/recreation/programs/accessibility/>)  
—National Trail Management Classes ([http://www.fs.fed.us/r3/measures/Inventory/trails%20files/Trail\\_Class\\_Matrix\\_1\\_31\\_2005.doc](http://www.fs.fed.us/r3/measures/Inventory/trails%20files/Trail_Class_Matrix_1_31_2005.doc))  
—Trail Designed Use and Managed Use Parameters ([http://www.fs.fed.us/r3/measures/Inventory/trails%20files/National\\_Design\\_Parameters\\_1\\_31\\_2005.doc](http://www.fs.fed.us/r3/measures/Inventory/trails%20files/National_Design_Parameters_1_31_2005.doc))
- International Building Code (IBC)—<http://www.iccsafe.org/>
- Public Rights-of-Way Accessibility Guidelines—<http://www.access-board.gov/prowac/>
- Recreation & Heritage Resources Integrated Business Systems (RHRIBS, formerly Meaningful Measures)—<http://www.fs.fed.us/r3/measures/>
- Recreation Opportunity Spectrum (ROS)—<http://fsweb.wo.fs.fed.us/eng/facilities/recopp.htm>
- Regional Recreation Accessibility Coordinators (RRAC)—<http://fsweb.mtdc.wo.fs.fed.us/toolbox/acc/documents/coord.htm>
- Region/Station Facilities Program Leaders—[http://fsweb.wo.fs.fed.us/eng/documents/fac\\_leaders.htm](http://fsweb.wo.fs.fed.us/eng/documents/fac_leaders.htm)
- Rehabilitation Act Section 504—<http://www.access-board.gov/enforcement/Rehab-Act-text/title5.htm>
- Soil Stabilizers on Universally Accessible Trails—<http://www.fs.fed.us/eng/pubs/pdf/00231202.pdf> (Username: t-d, Password: t-d) and <http://www.fhwa.dot.gov/environment/fspubs/00231202/>
- Trail Construction and Maintenance Notebook—<http://www.fs.fed.us/eng/pubs/htmlpubs/btm04232825/> and <http://www.fhwa.dot.gov/environment/fspubs/00232839/>
- Uniform Federal Accessibility Standards Accessibility Checklist—<http://www.access-board.gov/ufas/UFASchecklist.txt/>

- Universal Design Forest Service Policy, Forest Service Manual Section 2330.5—[http://www.fs.fed.us/im/directives/fsm/2300/id\\_2330-2005-2.doc](http://www.fs.fed.us/im/directives/fsm/2300/id_2330-2005-2.doc)
- Universal Trail Assessment Process—<http://www.beneficialdesigns.com/trails/utap.html#overview%20background>
- Wetland Trail Design and Construction—<http://www.fs.fed.us/t-d/pubs/htmlpubs/btm01232833/> (Username: t-d Password: t-d) and <http://www.fbwa.dot.gov/environment/fspubs/01232833/>
- Wilderness Access Decision Tool—[http://carbart.wilderness.net/docs/wild\\_access\\_decision\\_tool.pdf](http://carbart.wilderness.net/docs/wild_access_decision_tool.pdf)



# Tips in This Guidebook

## **Budget Tip**

Is cost an excuse? \_\_\_\_\_ 27

## **Construction Tips**

Avoiding unintended consequences \_\_\_\_\_ 23

What is a slope ratio? \_\_\_\_\_ 32

Surfacing materials \_\_\_\_\_ 34

Is it really sccessible? \_\_\_\_\_ 42

Accessible picnic yables \_\_\_\_\_ 48

Installing a pedestal grill \_\_\_\_\_ 49

Privacy screens \_\_\_\_\_ 67

What is a slope ratio? \_\_\_\_\_ 83

Measuring grade \_\_\_\_\_ 92

How long should the parking area be? \_\_\_\_\_ 53

What about inside benches? \_\_\_\_\_ 59

Railing design \_\_\_\_\_ 62

It's not a pit toilet if it's not in a general forest area. \_\_\_\_\_ 65

Toilet steps should be a design solution of last resort. \_\_\_\_\_ 68

Why is compliance required on both sides of a departure? \_\_\_\_\_ 76

How much harm is too much? \_\_\_\_\_ 78

What's feasible? \_\_\_\_\_ 79

If the trail isn't accessible, why does the warming hut have to be accessible? \_\_\_\_\_ 90

No Substitute for on-the-ground layout \_\_\_\_\_ 91

What is firm and stable? \_\_\_\_\_ 93

Determining when trail width is a limiting factor\_ 93

Applying the process \_\_\_\_\_ 95

## **Design Tips**

Where do conditions for departure apply? \_\_\_\_\_ 28

How much is too much? \_\_\_\_\_ 29

Looking at the full range of issues \_\_\_\_\_ 30

When should handrails be used on outdoor stairs? 33

Paving the wilderness? \_\_\_\_\_ 34

What is firm and stable? \_\_\_\_\_ 35

How wide should the access route be? \_\_\_\_\_ 36

How far down the beach must the access route go? 39

Unlisted features \_\_\_\_\_ 43

Forward reach and side reach \_\_\_\_\_ 44

Forward approach and side approach \_\_\_\_\_ 48

Parking for walk-in camping units \_\_\_\_\_ 52

Pedestrians in the driveway \_\_\_\_\_ 53

## **Maintenance Tips**

Improving accessibility through maintenance \_\_\_\_ 23

## **Terminology Tips**

Wheelchairs are not motor vehicles. \_\_\_\_\_ 8

What's the difference between a guardrail, a handrail, and a grab bar? \_\_\_\_\_ 15

What do you call a reroute? \_\_\_\_\_ 75



## About the Authors

**Janet Zeller** is the accessibility program manager for the USDA Forest Service, based in Washington, DC. She has worked in the field of accessibility for two decades and has worked for the Forest Service since 1991. She has helped develop and implement accessibility programs and policies at all levels of the agency. She also teaches accessibility and universal design for programs and facilities at a wide range of training sessions nationally. She holds a bachelor's degree in education from the University of New Hampshire and a master's degree from the University of Rhode Island.

**Ruth Doyle** is the forest landscape architect and assistant recreation staff officer at the Santa Fe National Forest, where she is responsible for managing the forest's recreation program. Ruth was the Forest Service's representative on the Access Board's Outdoor Developed Areas

Regulatory Negotiation Committee, the committee tasked with developing accessibility guidelines for picnic areas, campgrounds, beach access routes, and trails. She has a master's degree in landscape architecture from the University of Massachusetts, Amherst, and is a registered landscape architect in New Mexico.

**Kathleen Snodgrass** came to MTDC as a project leader in 2001 from the Nez Perce National Forest, where she had been the facilities architect for about 7 years. Before becoming facilities architect, she had worked in facilities, landscape architecture, land line, and general engineering for the Nez Perce National Forest. Kathleen also spent about 10 years working in highway design and construction with the Idaho Division of Highways after graduating from Washington State University in 1974 with a bachelor's degree in architectural studies.

## Library Card

Zeller, Janet; Doyle, Ruth; Snodgrass, Kathleen. 2006. Using the Forest Service accessibility guidelines for outdoor recreation and trails. Tech. Rep. 0623-2801-MTDC. Missoula, MT: U.S. Department of Agriculture Forest Service, Missoula Technology and Development Center. 110 p.

This guidebook will help users integrate accessibility into planning, design, construction, and maintenance of outdoor recreation facilities and trails while maintaining the natural setting. It provides detailed information about accessibility requirements in an easy-to-use format, with photos, illustrations, design tips, hotlinks, and sidebars. This guidebook will also help Forest Service personnel, partners, contractors, and Federal and State

agencies working in cooperation with the Forest Service understand how to apply the Forest Service Outdoor Recreation Accessibility Guidelines and Forest Service Trail Accessibility Guidelines.

Keywords: ABA, acronyms, ADA, Americans with Disabilities Act, Architectural Barriers Act, beaches, campgrounds, conditions for departure, definitions, disabilities, Forest Service Outdoor Recreation Accessibility Guidelines, Forest Service Trail Accessibility Guidelines, FSORAG, FSTAG, general exceptions, grills, handpumps, overlooks, parking spaces, picnic tables, showers, slopes, surfaces, terminology, toilets, trails, universal design, wheelchairs

---

**Electronic copies of MTDC's documents are available on the Internet at:** <http://www.fs.fed.us/t-d>  
(Username: t-d, Password: t-d).

**For additional information, contact Kathleen Snodgrass at MTDC.**

Phone: 406-329-3922

Fax: 406-329-3719

E-mail: [ksnodgrass@fs.fed.us](mailto:ksnodgrass@fs.fed.us)

**Forest Service and Bureau of Land Management employees can search a more complete collection of MTDC's documents, videos, and CDs on their internal computer networks at:** <http://fsweb.mtdc.wo.fs.fed.us/search>.